

Pantera



Pantera 4502 self-propelled sprayer

Designed for performance



With its teamwork of design and performance, the Pantera 4502, registered in the category "transportation design/special vehicles", convinced and enlightened the iF jury which consisted of experts and designers from all over the world. The evaluation criteria for the jury included, in addition to design, quality of workmanship and the choice of materials, the degree of innovation and environmental impact, as well as the functionality, ergonomics, visualisation of its intended use and safety.



- 
 "... completely automotive driving mode, even when spraying"
 (profi 11/2011)

The Pantera 4502 self-propelled sprayer features a tank volume of 4,500 l and is available with the Super-L2 sprayer boom in working widths of 21 to 40 m. Thanks to the wide variety of chassis types; Pantera, Pantera-W and Pantera-H, different demands with regard to track width and ground clearance can be fulfilled. This is especially beneficial to agricultural contractors and larger farms.



Pantera 4502

Highly intelligent

	Page
Top features	4
Intelligent in-cab management	6
Intelligent operational management	8
Intelligent chassis and steering management	18
Intelligent drive-line management	26
Intelligent plant protection management	30
Standard execution	50
Practical assessment	51
AMAZONE Service	52
Technical data	54

Spray liquid tank with
4,500 litres

Boom widths of
21 to 40 m



AmaSwitch or
AmaSelect

individual nozzle switching

Super-L2

sprayer boom in lightweight design

Hydrostatic drive from

0 to 50 km/h



Top features:

- ⊕ Unique tandem chassis – for a smooth and horizontal boom ride and better stability on slopes
- ⊕ Intelligent chassis management with 2-wheel, 4-wheel and dog leg steering – for even more manoeuvrability
- ⊕ Chassis options of Pantera-W and Pantera-H – for more flexibility in crop rotations (track width/ground clearance)
- ⊕ Pantera⁺ drive concept with alternative drive wheel gearboxes available for all chassis types– for extreme terrain
- ⊕ Infinitely-variable hydrostatic single range drive – for speeds from 0 to 50 km/h
- ⊕ Intelligent drive management with powerful engines in 3A or 4 country-specific emission levels
- ⊕ Intelligent engine management with either ECO-mode or Power-mode – for even better performance
- ⊕ Intelligent cab ergonomics – for an improved view and even better driving enjoyment
- ⊕ Intelligent operation management with up-to-date operator terminals and AmaPilot⁺ multi-function joystick
- ⊕ Intelligent crop protection management with fully automatic DistanceControl boom guidance – for the optimum height guidance of the boom
- ⊕ AmaSwitch and AmaSelect individual nozzle switching as an optional extra– for 50 cm part-width section control

Country-specific engines

with **3A** or **4**
emission levels

6-cylinder diesel engine with

160 kW/218 HP

maximum power rating



MORE INFORMATION
www.amazone.net/pantera

Get in and drive off! But above all, stay relaxed

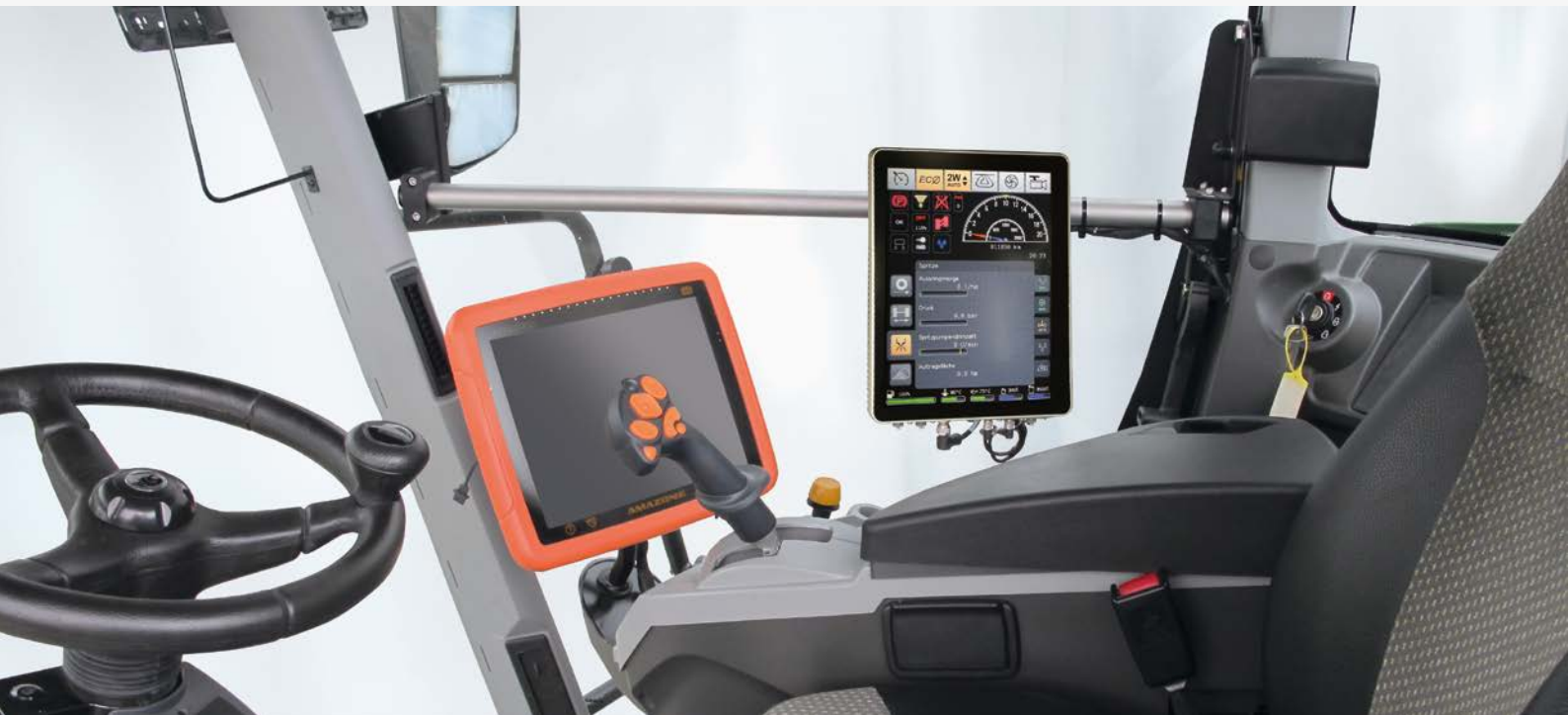

You will enjoy every working day...

...when you sit in this cab:

- ✔ Superb sound insulation
- ✔ Convenient, wide access with hydraulically folding ladder
- ✔ Electrically adjustable and heated exterior mirrors
- ✔ Additional mirror for best view of the front wheel
- ✔ In-cab air filter
- ✔ Automatic air-conditioning
- ✔ Air-cushioned comfort seat with multiple adjustment possibilities
- ✔ Spacious, folding passenger seat
- ✔ Height and longitudinally adjustable arm rest with integrated controls
- ✔ Adjustable steering column for rake and height
- ✔ Large cool box under the seat
- ✔ Document compartment
- ✔ CD radio with Bluetooth hands-free telephone facility
- ✔ Sun visors for front and rear windows
- ✔ Optional equipment: Activated carbon filters or Category 4 cab with air filtration

❗ "The Pantera's cab is manufactured by Claas. It is spacious and, above all, pretty quiet."

(traction magazine "Working Test Pantera 4502-H" · 2/2015)



Ideal lighting for the optimum visibility, even at night

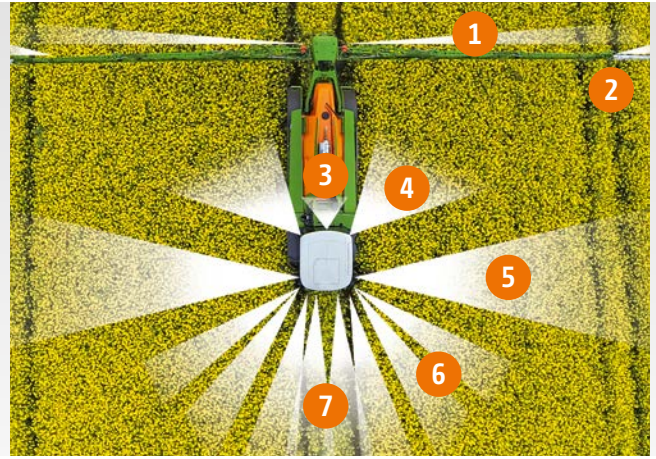

Feel at home – by day and night

The lighting concept of the Pantera offers you, the driver, the best view of the road, the field and the machine even at dusk or at night.

Category 4 cab with air filtration

For the best air quality under all applications, AMAZONE offers, as an option, a Category 4 cab with air filtration in accordance with EN 15695. This means positive pressure circulation within the cab via all necessary filter inserts, so that the ingress of dust and droplets is prevented. In this way the filtering provides additional safety for the operator by ensuring clean air in the cab.



As standard with LED rear lights (for Pantera with Tier IV engines)

Lighting equipment for long yet safe working periods

- 1) LED work lights (option)
 - 2) LED individual nozzle lighting (option)
 - 3) Tank lid spot light
 - 4) Boom work lights (2 spot lights)
 - 5) Side view work lights (2 spot lights)
 - 6) Side work lights (4 spot lights)
 - 7) Front work lights (4 spot lights)
- Optional LED cab roof lights for the positions 4 to 7

“... offers perfect all-round visibility“
(profi 11/2011)



AmaPilot/AmaPilot⁺ multi-function joystick for vehicle and sprayer

Many functions to the one hand

Whether using the drive lever or operator controls for the spraying functions - with the multi-function joystick in the Pantera - many functions come safely and comfortably to one hand.

“Get in and drive off“ is the motto! Drive to the machine is infinitely variable and has an intuitive feel via the multi-function joystick. In cruise control, and with the maximum forward position of the multi-function joystick, the Pantera achieves speeds of up to 50 km/h on the road, and in the field, the pre-selected desired operating speed (the permissible maximum speed may vary, depending on the national road traffic regulations).

Pulling the control lever to the rear actuates the newly developed hydrostatic dual circuit braking. This automatically actuated hydraulic auxiliary braking assists the driver in all situations. The highest sensitivity on start-up and when manoeuvring is guaranteed. This is normally sufficient for a sensible reduction of the speed on the road or in the field. Only in exceptional cases does one need to operate the foot brake as well.

You can also control the entire steering management via the AmaPilot/AmaPilot⁺ multi-function joystick: on/off of the 4-wheel steer and manual dog-leg steer or re-alignment in sloping terrain are all possible.

Of course, many of the sprayer features can be operated via the multi-function joystick: Part-width section and boom control, additional functions such as boundary nozzle on/off and the +/- % spray rate increase button.

The benefits of AmaPilot:

- ✔ Perfect ergonomics
- ✔ Almost all the functions directly to hand via the 3 levels
- ✔ Settable palm rest

Additional benefits with AmaPilot⁺ * :

- ✔ Freely-assignable button layout

* Standard on Pantera with Tier IV engine emissions



- ❗ "We also liked the new AmaPilot multi-function joystick, which, in addition to forward speed and cruise control, also accommodates the most important sprayer functions (part-width section shut-off and boom actuation, boundary nozzle switching and matching of the application rate)." (traction magazine "Working Test Pantera 4502-H" · 2/2015)

- ✔ AmaPilot⁺ multi-function joystick

- ❗ "The joystick fits in the hand perfectly " (dlz magazine "Test report Pantera 4502" 2/2016)

- ✔ Simply brilliant – the AMADRIVE touch-screen for vehicle operation and the monitoring of the Pantera.



Everything under control, everything to view – with AMADRIVE for all functions

With just a light pressure on the touch-screen of the AMADRIVE you can control the following functions:

- ✔ Cruise control
- ✔ Engine management with Eco or Power Mode
- ✔ Headland-management
- ✔ Track width adjustment
- ✔ Adjustment of the spray pump speed
- ✔ Control of the work lighting on the vehicle and booms

Via the AMADRIVE display a variety of data can be recalled as well:

- ✔ Forward speed and engine revs
- ✔ Fuel tank level and engine temperature
- ✔ Diagnostic data of engine and hydraulic system

- ! "The full overview means the AmaDrive touch screen provides the driver with the most important data" (traction magazine "Working Test Pantera 4502-H" · 2/2015)

Optionally available camera systems

The pictures from the optionally available rear-view reversing camera and the camera for the right front wheel are also displayed on the high-quality colour screen.

- ✔ Large 135° viewing angle
- ✔ Camera with heating and lotus coating
- ✔ Clear picture even after dark thanks to infrared night vision technology
- ✔ Automatic back light function





ISOBUS terminals

ISOBUS is the name for a communication standard, valid world-wide, between operator terminals, tractors and implements on the one hand and agricultural office software on the other hand. That means with one terminal you can control all ISOBUS compatible implements.

The self-propelled Pantera 4502 can be operated via different AMAZONE ISOBUS terminals:



AMAZONE AMATRON 3
5.6" size screen



AMAZONE CCI 100
8.4" size touch screen



AMAZONE AMAPAD
12.1" size touch screen

Other ISOBUS terminals

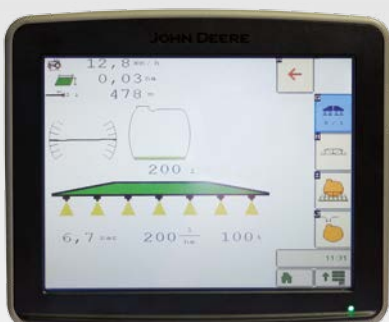

e. g. John Deere GreenStar



e. g. Müller COMFORT terminal

MEMBER OF



✔ AmaPilot/AmaPilot+ multi-function joystick

Actuating the boom and control chest functions is particularly comfortable via the AmaPilot+ multi-function joystick. All the functions in the operation menu can also be actuated via the AmaPilot+ multi-function joystick or other ISOBUS joysticks (AUX-N).



The benefits thanks to ISOBUS:

- ⊕ AMAZONE ISOBUS sprayers are UT 2.0 certified and as such can be operated via any ISOBUS terminal with UT 2.0.
- ⊕ All AMAZONE ISOBUS terminals and job computers support the AUX standard enabling the keys to be assigned on any AUX-N compatible multi-function joystick.
- ⊕ AMAZONE ISOBUS sprayers can be accessed with any ISOBUS compatible Section Control licence.

Special characteristics of AMAZONE ISOBUS sprayers:

- ✔ Up to three user profiles and individual interfaces for different drivers can be created.
- ✔ The operation menu can be optimally matched to the differing numbers of keys on other ISOBUS terminals.
- ✔ Any machine function can be freely positioned in the menu set-up.
- ✔ Complete documentation via TaskController (ISO-XML). As an alternative to documentation via TaskController, the simple recording of field data (worked area, required time and applied rate) is possible. The recorded data can then be captured as a screen shot and then exported via a USB stick.

Important information

Please note that when working with other ISOBUS terminals, additional Section Control software, for example, from the tractor manufacturer, is normally necessary. This is not usually included in the standard version of other ISOBUS terminals.

2-terminal solution

A twin-terminal solution with the simultaneous use of a tractor ISOBUS terminal and AMATRON 3 or CCI 100 is recommended if the tractor terminal does not support the Section Control function or if you intend to use the sprayer via AMATRON 3 or CCI 100 and a separate screen.

AMATRON 3 operator terminal



AMATRON 3 operator terminal

AMATRON 3 is fully downwardly compatible to AMATRON⁺ and upwardly compatible to the ISOBUS standard and forms a bridge between the non-ISOBUS and ISOBUS world.

AMATRON 3 enables the user to safely and comfortably operate both AMAZONE implements with AMATRON⁺ (AMABUS) and implements that meet the ISOBUS standard. Needless to say, even if these are not from AMAZONE.

The terminal for all crop protection functions

Accurate metering and simple operation

The AMATRON 3 operator terminal allows the fully automatic regulation of the pre-set application rate (l/ha). Rate changes are possible in pre-selected % steps.

Thanks to its clear, simple and logical handling and the back-lit keys, this modern terminal is especially operator-friendly. For monitoring the system, a high resolution, high contrast and anti-glare display is utilised. The very compact dimensions of the computer mean little space is required in the tractor cab.

By using two flow meters, the application rate is extremely precisely maintained, particularly at low spray rates.

The terminal features the following functions:

- ✔ ISOBUS machine operation
- ✔ AMABUS machine operation
- ✔ Tractor ECU function
(Interface for speed and PTO shaft)
- ✔ TaskController job management for documentation
- ✔ Import/Export of field data via a USB stick
- ✔ GPS-Switch automated part-width section control (optional)
- ✔ GPS-Track parallel guidance system (optional)
- ✔ Optional external light bar display for GPS-Track parallel guidance
- ✔ GPS-Maps application map module (optional)
- ✔ ASD interface via RS232 (nominal rate transfer), e.g. for N sensors



Standard functions:

- ✔ Overall and part-width section on/off
- ✔ Digital pressure indication
- ✔ Digital fill-level indicator
- ✔ Display of boom position and locking status

Special functions:

- ✔ Foam marker
- ✔ End or boundary nozzle on/off control
- ✔ Pre-select fold for the independent boom folding
- ✔ Profi-fold for independent boom folding or boom tip angling (only 1 tractor control valve required)
- ✔ DistanceControl – automatic boom guidance
- ✔ Comfort-Pack – remote controlled liquid flow circuit
- ✔ GPS-Switch, GPS-Track and GPS-Maps



✔ AMACLICK

Special crops and bed work often require the on/off switching of the individual part-width sections in the middle of the boom. AMACLICK is an additional ergonomic control unit that can be used either in conjunction with the multi-function joystick or also though as a standalone system alongside an ISOBUS terminal.

CCI 100 terminal

The benefits

The CCI ISOBUS terminal from AMAZONE is the result of the cooperation with several other manufacturers of agricultural machinery who are joint participants in the Competence Center ISOBUS e.V (CCI). With CCI, AMAZONE and its partners have laid the foundation to introduce ISOBUS into practice. The CCI is the basis to convert all AMAZONE machinery and implements successively to the ISOBUS standard.

- ✔ The bright 8.4" colour display with its high screen resolution and ambient light sensor matches the brightness automatically to the light conditions. This avoids the driver in twilight or at night being blinded by too bright a display.
- ✔ Easy input via the operator-friendly touchscreen display, or via the softkeys.
- ✔ Fatigue-free operation at night is assisted by the back-lighting of the keys which are also connected with the light sensor.
- ✔ The proven AMAZONE one-handed operation is still possible because the function of the "soft keys" can be simply mirrored.
- ✔ For intuitive menu guidance and the convenient input of values and text, the terminal is provided with a high-quality touch screen.

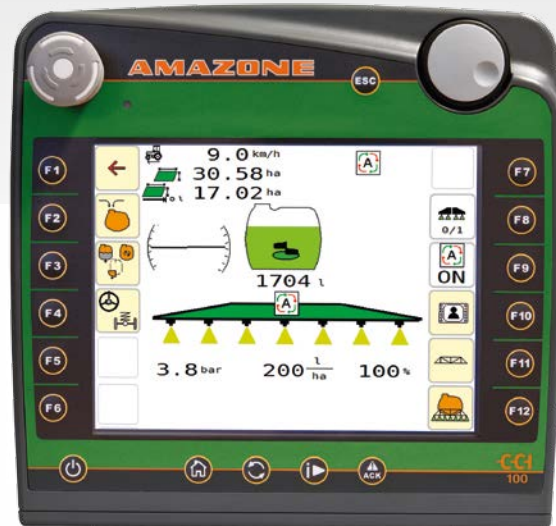

- ✔ For the direct quick, input and adjustment of the input values, a scroll wheel with actuating function is ergonomically integrated in the housing.

The terminal includes the following functions:

- ✔ ISOBUS machine operation
- ✔ Tractor ECU function (Interface for speed, PTO shaft and lower link position)
- ✔ CCI.Control job management for documentation
- ✔ CCI.Command (optional):
 - automatic part-width section shut-off CCI.Command.SC
 - parallel guidance aid CCI.Command.PT
- ✔ Application maps supported in ISO-XML format
- ✔ USB interface for data exchange
- ✔ Interface for the connection of a GSM modem
- ✔ ASD and LH5000 interface via RS232 (nominal rate transfer), e.g. for N sensors
- ✔ Camera function CCI.Cam



- ✔ External light bar for CCI.Command.PT parallel driving aid
 - As a possible addition, an external lightbar is available which can comfortably be coupled with CCI Command PT. The external lightbar can be positioned freely in the tractor cab. The only precondition for its utilisation is the activation of the Parallel Tracking module in CCI.Command.

AMAPAD

An especially comfortable method of controlling agricultural machinery

The new dimension in control and monitoring

With the AMAPAD operator terminal, AMAZONE offers an entirely new and high-class solution for GPS application such as automated GPS based part-width section control and Precision Farming applications.

AMAPAD features an especially ergonomic, 12.1" touch screen. With the unique "Mini-View" concept, applications that do not need to be actuated but which, however, need to be monitored, are clearly shown at the side. If needs be, these can be enlarged by "finger tip" widening. The possibility also exists to customise the display, a feature which rounds off the exceptional layout of this operator terminal.

The terminal includes the following functions:

- ✔ ISOBUS implement operation
- ✔ TaskController job management for documentation
- ✔ automated GPS-Switch pro part-width section control
- ✔ integrated light bar for GPS-Track pro parallel steering aid
- ✔ as an option: upgradable to automatic steering
- ✔ GPS-Maps pro application map module
- ✔ RS232 interface via SCU adapter (for data exchange)
- ✔ two USB interfaces for data exchange
- ✔ WLAN mode (via USB adapter)
- ✔ GPS output



In addition to GPS-Switch pro part-width section control, a high-quality professional manual light bar guidance system is also installed as standard. GPS-Track can also be upgraded to an automated steering system.

GPS-Track Auto for AMAPAD (automatic steering)

The optional system is composed of a specially-developed hydraulic kit for the Pantera (steer-ready package) along with an AGI-4 receiver with EGNOS or with an optional RTK correction signal.

The characteristics of AMAPAD:

- ✔ screen made from toughened glass
- ✔ housing made from impact-proof plastic
- ✔ extra-narrow rim for maximum visibility
- ✔ flush finish, no penetration of dust / humidity



Yet more precision

with GPS-Switch, GPS-Track and GPS-Maps!



GPS-Switch for AMATRON 3 and AMAPAD

This GPS assisted on-board computer system automates the exact control of the machine on the headlands, around the field border and when spraying in wedges. The working width and the arrangement of the part-width sections are taken into account.

The automatic GPS-Switch part-width section control offers precision, comfort and safety: simply select the desired

degree of overlapping and leave the switching off in automatic mode. So, even more difficult circumstances, such as wider working widths, limited visibility at dawn or dusk or in high crops can be mastered. In addition: you save on the cost of plant protection agents and also help the environment. And the driver can fully concentrate on monitoring the performance of the sprayer.



-  The combination of either AmaSwitch or AmaSelect with GPS-Switch results in individual nozzle switching to provide even more precision due to the 50 cm part-width section control. For more information, please see pages 42-45

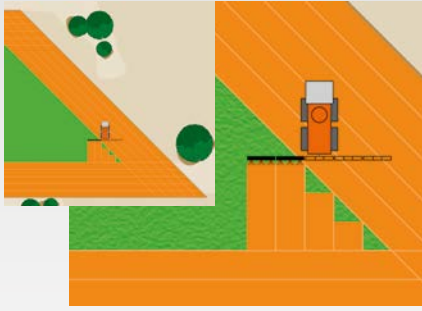

Degree of overlap 0 %

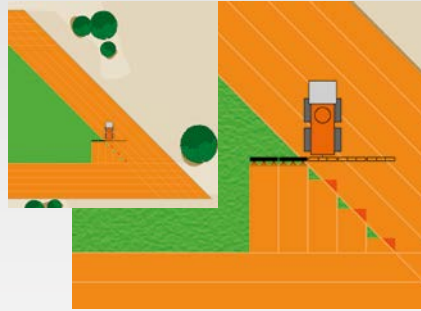

Degree of overlap 50 %

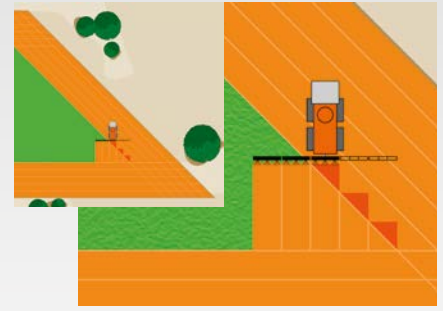

Degree of overlap 100 %



GPS-Maps for AMATRON 3 and AMAPAD

These two terminals allow the GPS-based processing of application maps in a Shape file format.

The direct application rate can be used or the amount of spray agent. With the terminal, the spray rates can still be adapted.

As Task Controller is provided as standard, application maps can also be processed in the ISO-XML format.



GPS-Track for AMATRON 3 and AMAPAD

The GPS-Track parallel driving aid turns out to be an enormous advantage for easy orientation in fields. It features various track modes, such as A-B line and contour travel and an obstacle function. The bouts are numbered all the way across. The deviation from the true line is shown on the display – clear steering guidance that helps keep you on track. Also the distance to the next tramline is shown precisely, providing the ideal guide, for example, when locating the correct maize row.



- ✓ AGI-4 receiver for part-width section control and automatic steering (option)

Chassis management



- ✔ Exclusive: automatic suspension management
Softer settings for constant forward speeds
Harder setting during acceleration and when manoeuvring

The outstanding longitudinal tandem chassis

AMAZONE Pantera

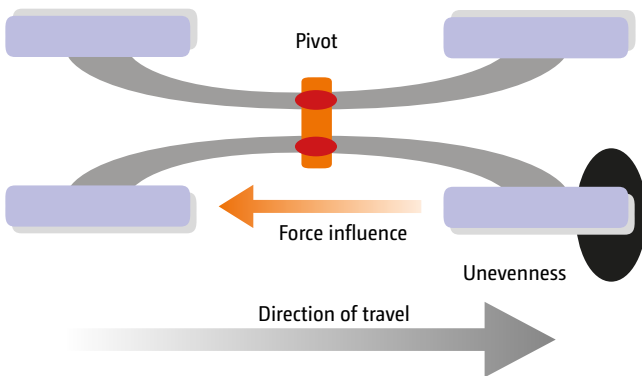

Conventional chassis

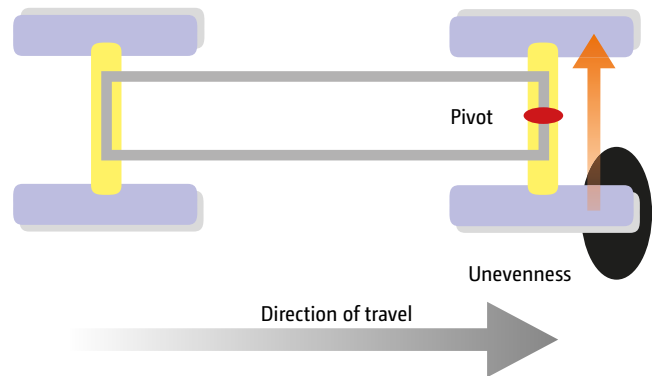

- ✔ The unevenness under the right hand front wheel is compensated by the elongated tandem. The pivot point is only slightly lifted. Only a slight transmission of the forces onto the frame.

Pantera – with light-footed intelligence

The special tandem chassis of the Pantera not only ensures the perfect adaptation to ground undulations, but also a high boom stability – especially of course, in sloping terrain. Thanks to the level regulated hydro-pneumatic suspension, the Pantera operator also enjoys the maximum level of comfort.

The combination of this unique chassis design and the proven AMAZONE boom suspension additionally ensures an optimally smooth boom ride even under the most arduous of conditions.

The advantages of the Pantera chassis concept:

- ✔ Superbly strong frame with proven chassis components
- ✔ Pendulum frame for optimised soil contact and reduced slip
- ✔ Comfortable and safe driving behaviour from the longitudinal tandem
- ✔ Hydro-pneumatic suspension system with level regulation
- ✔ Reliable hydraulic system – no air regulation
- ✔ Smooth boom ride, reinforced by additional boom parallel damping
- ✔ Infinitely variable track width adjustment
- ✔ Large ground clearance
- ✔ Headland management for both steering and boom functions means stress relief for the driver and gentle boom treatment
- ✔ Narrow transport width, compact in road traffic

Traction control as standard

The drive torque of the four wheel motors is constantly being monitored electronically and then regulated to ensure the optimum vehicle behaviour even under difficult conditions. Power-hunger, physical differential locks are omitted. In the field, even in wet conditions, you will always comfortably get through. However, also on the road ASR always ensures a safe trip.

Pantera 4502, 24 m, 520/85R38

Unladen weight 9,850 kg

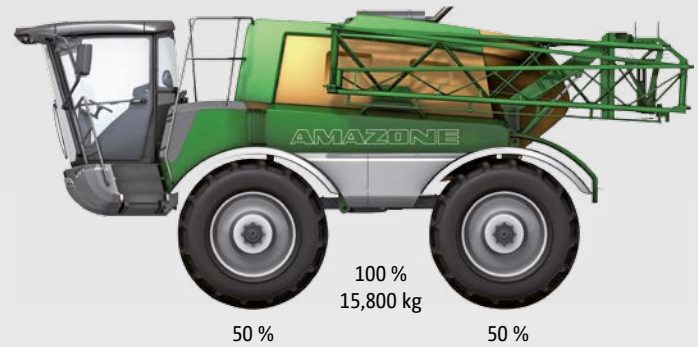

Weight distribution when full and with the booms folded out

Weight distribution at the optimum!

The even weight transfer to the front and rear wheels is the ideal pre-condition for efficient traction.

This is why the Pantera 4502 features, with a full tank, an optimum weight distribution of approximately 50 % - 50 % to each the front and rear axle. Depending on the tank level and the boom type, the weight distribution varies only by around 5%.

Nearly unbounded – exceptional ground clearance

The big ground clearance of 1.20 m also proves to be an important advantage for the Pantera in practice. With Pantera-H, a ground clearance of even 1.70 m. This is an advantage that is of benefit for you especially when spraying rape at flowering, or even also in taller maize crops – a more gentle plant treatment can hardly be possible.



Track width adjustment in no time at all



Pantera 4502

The fully automatic track width adjustment, fitted as standard, enables you, for example as a contractor, to react quickly on the various demands of the different customers. Once the desired track width has been pre-selected, the exact centimetre precise setting is carried out automatically. To protect the drive gearboxes these are provided with additional covers



✔ Standard with wheel motor covers

Pantera 4502

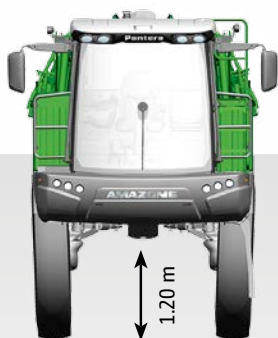

Track width adjustment:
1.80–2.40 m at a clearance of 1.20 m

Pantera 4502-W

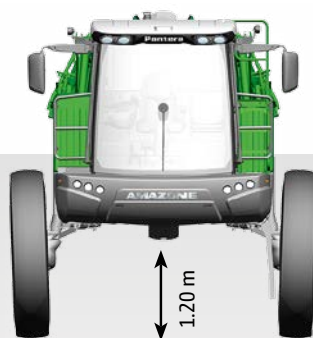

Track width adjustment:
2.25–3.00 m at a clearance of 1.20 m

Pantera 4502-H

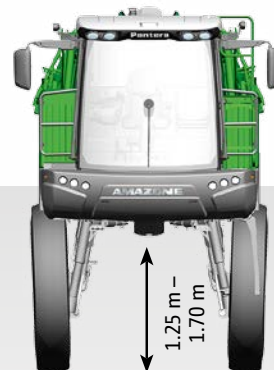

Track width adjustment:
1.80–2.40 m at a clearance of 1.25 m
2.10–2.60 m at a clearance of 1.70 m

Pantera 4502-W

The Pantera 4502-W is equipped with a track width adjustment from 2.25 m to 3.00 m. In "Controlled Traffic Farming" systems this option makes an excellent alternative. This equipment level is also of benefit for when

operating in potato crops without tramlines as four rows of potatoes fit underneath the machine resulting in high stability and it also ensures minimal plant damage.



Pantera 4502-W

The self-propelled Pantera 4502-H

The success story continues



Increased flexibility

At the touch of a button on the operator terminal, the driver can lift the machine up to a ground clearance of 1.70 m. With the machine in the lifted position, the track width can be adjusted between 2.10 and 2.60 m. In this way, the Pantera 4502-H, despite its higher centre of gravity, proves to be highly stable and at the same time can be used flexibly in a variety of crops and row spacings.

One unique feature of the AMAZONE solution is the still very broad track width range. So in normal operation where a ground clearance only 1.25 m is required, the track width of the machine can be adjusted from 1.80 to 2.40 m. Especially for agricultural contractors, who wish to offer a flexible crop protection service across a greater variety of customers and crops, they are still able to operate at narrower track widths in small field regions. With the Pantera 4502-H the range of crop protection applications can be significantly extended and thus increases the machine's capacity.



Pantera-H chassis

- ✔ This variable track width adjustment allows it to travel in a standing maize or sunflower crop. In this way, even with different row spacings, the wheels do not run over any plants. (traction magazine "Working Test Pantera 4502-H" · 2/2015)



Pantera 4502-H with lift module 700

1.70 m ground clearance

3.70 m lift height

Lift module

The optionally available 700 lift module enables the Super-L boom to lift by another 70 cm. In conjunction with this lift module, the Pantera-H provides an application height of 3.75 m – measured from the bottom edge of the nozzle. The lift module is available on all chassis variants.

Automatic track guidance

In addition to the automatic steering system via GPS, the Pantera 4502-H can also be equipped with the row sensing system from Reichardt. This is optimally suited for when guiding the Pantera in row crops, such as, for example, maize or sunflowers. As an alternative, the ultra-sonic sensor system from Reichardt can be utilised for automatic track guidance.

More protection for machine and plants

For an even further improved protection, AMAZONE offers, in addition to the standard wheel motor guards, with the drive wheel gearbox covers, the crop dividers and the underbody protection plate, three further special options for the Pantera-H.

Crop-saving SunflowerKit

The SunflowerKit, specifically for the Pantera-H, has been developed so as to be able to carry out plant protection and fertiliser applications in tall crops without causing too much plant damage. The kit consists of crop dividers, wheel housings and a shaped, flexible underbelly sheet. The crop dividers precisely separate the plants between the rows directly in front of the tyres and, thanks to the special shaped profile of the cover and the properties of the flexible material, the plants are guided between the wheels in a funnel shape to the machine centre and pass unhindered underneath the machine.



Wheel motor covers



Drive wheel gearboxes covers

Crop divider



SunflowerKit

Steering management:

It has to be manoeuvrable, compact and flexible!



2-wheel steer



4-wheel steer



Dog leg steer

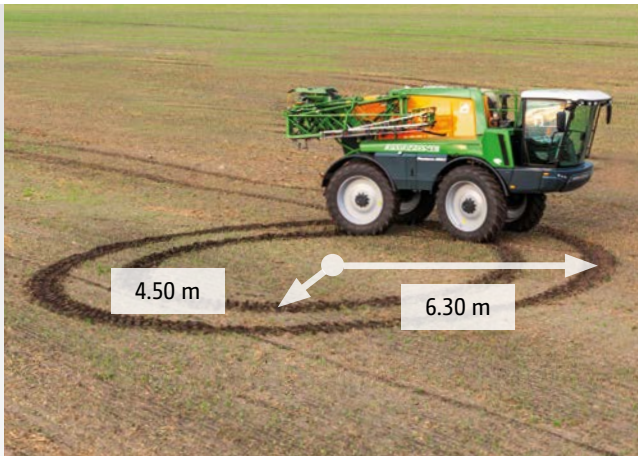

Be relaxed when working – even on the headland

In spite of the vehicle size, the minimal turning circle of the Pantera is only 4.50 m when in 4-wheel steer. This is helped by a short wheelbase and sharp steering angle. With this superb manoeuvrability, the daily acreage outputs can be optimised enormously, especially in small fields. The switching between 4-wheel and 2-wheel steer is carried out via the multi-function joystick.

The “dog leg steer” function facilitates perfect operation to keep within the wheel marks, even when working on sloping terrain. The steering re-adjustment is also done via pressing a button on the multi-function joystick. Also, in wet conditions and on sensitive soils, the off-set track driving using the dog leg steer proves to be a decisive advantage.

The Pantera shows its intelligence even on the headland: Once the headland-management is activated in the AMADRIVE terminal, the all-wheel steer is automatically switched on when the sprayer is switched off and when the boom is raised. After switching on again, out from the headland, the two-wheel steer again ensures the perfect boom ride.

✔ Central lubrication

The fully automatic central lubrication system ensures that the correct maintenance schedule is adhered to, yet with a minimum of downtime and expenditure. With the Pantera, all the grease points are covered including the parallelogram frames.

The speed-related regulation of the all-wheel steer is the guarantee of optimised horizontal boom guidance. At speeds of more than 8 km/h the steering angle is automatically reduced, preventing an extreme acceleration of the boom in the direction of travel.

As a special option, AMAZONE offers solutions for GPS-assisted automatic steering. This enables you to obtain an exact track-to-track accuracy of only a few centimetres.

Intelligent logistics

With the optionally offered drawbar, you can pull a two axle water tanker of up to 16 t total weight behind the Pantera. This makes for very high daily outputs, even when used as a one-man operation.



Drive-line management with optimised fuel efficiency

Pantera – high-powered intelligence

The heart as a unit: engine and hydrostatic drive

Deutz 6-cylinder diesel engine with a maximum output of 160 kW (218 HP)

- ✔ Turbocharger with intercooler
- ✔ Common-Rail injection technology
- ✔ 6.06 litres capacity
- ✔ Country-specific compliance to Tier 3A or 4 engine emissions

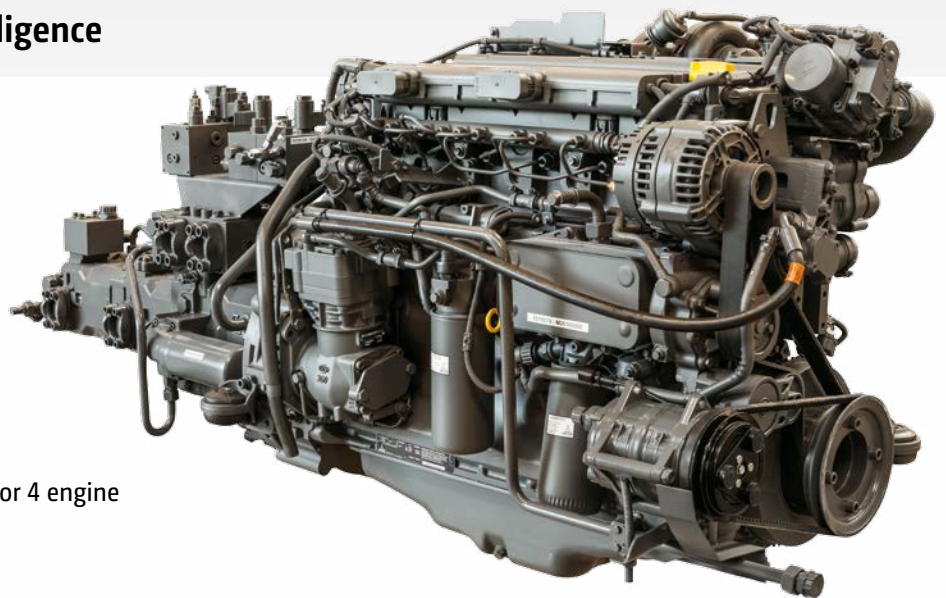

Your benefits:

- ✔ Infinitely variable hydrostatic drive from 0 to 50 km/h (the permissible maximum speed may vary, depending on the local road traffic regulations)
- ✔ State-of-the-art fuel management on the road and in the field with ECO and POWER mode
- ✔ Tailor-made speed regulated radiator fan drive
- ✔ Proven Deutz technology with a comprehensive service network

New exhaust gas level Tier IV engine

With this new engine, AMAZONE relies on exhaust gas recirculation with a diesel oxidation catalyst and diesel particulate filter – all of which help in saving the environment. The diesel particulate filter is continuously regenerating during operation. The SCR catalytic converter reduces, with the aid of a diesel exhaust fluid (DEF) injection, the levels of nitrogen oxide. The new 20 litre DEF tank is positioned at the side of the 230 litre diesel tank. The DEF consumption amounts to approximately 2.5% of the fuel consumption, meaning that the DEF tank only requires refilling every 3 or 4 diesel tank fills.



- ✔ Practical tank access steps for Pantera with Tier IV engines

The benefits of a clever cooling system:

- ✔ revs on demand
- ✔ at low power requirement and cool temperatures the fans are even switched off
- ✔ Layout beyond the reach of dirt
 - left hand: charge air, hydraulics
 - right hand: engine, air-conditioning

**Operation at optimum fuel saving: ECO or POWER**

The new and optimised engine revs regulation enables you to operate the Pantera always at the optimum fuel consumption efficiency. If ECO mode has been selected in the AMADRIVE terminal, the engine searches for the optimum operating point for torque and revs, depending on the relevant driving situation.

When spraying on the flat, an engine rev reduction down to 950 RPM is possible. The automatic speed adaptation takes place constantly and sensibly between 950 and 2,000 RPM. If, however, you are working on steep slopes in hilly terrain, reinstate maximum output of up to 2,000 RPM via the POWER mode.

Example in ECO mode

- 1) **On the flat, around 80 KW is necessary**
the engine runs at 1,050 RPM
- 2) **The machine travels up hill: the torque increases under load**
the speed remains constant
- 3) **The slope carries on: the power requirement increases to 120 kW**
the engine control automatically increases in the revs to 1,500 RPM
the speed remains constant at a slightly increased fuel consumption

- ❗ “The Amazone Pantera impresses by its low diesel consumption, the minimal noise level, the good weight distribution and sufficient payload.”
(profi 12/2011)

Infinitely variable power

The powerful Deutz 6-cylinder diesel engine with Common-Rail injection technology provides 218 HP and impresses by its high performance yet low fuel consumption. Thanks to the modern hydrostatic drive mechanism, you can drive the Pantera with absolute infinite variability.

This system allows, even at a low engine speeds, high start-up torques and a very dynamic acceleration.

Good power/weight ratio

Of course, also the low unladen weight of the Pantera 4502 (9,900 kg with a 24 metre boom gives a good power/weight ratio) is an advantage for a low fuel consumption. So, the fuel tank volume of 230 litres enables high work rates over long days.



- ✔ New integrated DEF tank for Panteras with Tier IV engines

Brake management:

Your safety is paramount!



Pantera – safe intelligence

When the speed is reduced the hydrostatic dual circuit braking of the Pantera is activated and elegantly brakes the vehicle down to a complete stop.

Especially noticeable here is that with the hydrostatic deceleration of the vehicle the built-in trailer braking system is also energised early.

With this technology you always brake safely on the road. The air braking system is an important safety feature that enables safe braking, for example, on an emergency stop from 50 km/h or with a filled water tanker on behind (the permissible maximum speed may vary, depending on the local road traffic regulations).

❗ “The Amazone Pantera shows very good driving behaviour with a speed of 42 km/h at just 1400 revs.“
(profi 12/2011)

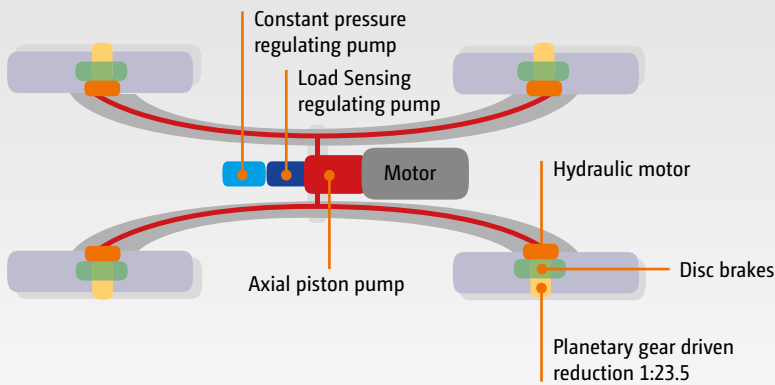

Pantera – flexible intelligence

There is a clear division of responsibilities for the high quality Linde hydraulic pumps. Because of the large diameter wheels, very high torques are needed, especially when starting off from stationary. The intelligent drive concept of the Pantera doesn't build up these high forces hydraulically but translates these into mechanical forces via the planetary gearboxes. This makes for a guaranteed drive when working in unfavourable ground conditions and when driving off.

The electrically adjustable wheel motors are, depending on the driving situation, always optimally set, no matter whether maximum torque or maximum revs are required.

Pantera⁺ drive concept – powerful intelligence

With the Pantera⁺, AMAZONE offers a drive concept that is particularly suitable for that extreme terrain found in hilly areas. The standard drive wheel gearboxes, across all of the Pantera range, are replaced by an alternative gearbox with a drive ratio of 1:30 (instead of 1:23.5). Due to these alternative gearboxes, the Pantera⁺ has a smaller drive ratio and so therefore, if required, considerably more torque.

The benefits of the Pantera⁺ drive concept:

- ✔ Up to 25 % more climbing ability
- ✔ Copes on slopes up to 34 %

Quick-running hydrostatic transmission with reduction gear at the wheel



- ✔ High torque at all times
- ✔ No speed change steps
- ✔ Possibility of larger wheel diameters
- ✔ The adjustable axial piston pump delivers the oil flow to the hydraulic motor
- ✔ Every hydraulic motor is individually speed regulated (traction control)
- ✔ A fixed reduction ratio in the planetary gearboxes drive the wheels

Intelligent spray liquid management: integrated into the total concept





Optimised for professional use

The 4,500 litre spray agent tank (actual volume 4,800 litre), deeply positioned in the frame, ensures a favourable centre of gravity and an even weight transmission on to all four wheels of the Pantera. The spray agent and fresh water tank consist of high grade glass fibre reinforced plastic with smooth internal and external walls. The low positioned outlet sump ensures smallest residual volumes even in sloping terrain. The electronic fill-level indication and the four rotating high pressure nozzles for the internal cleaning are part of the standard equipment.

The 500 litre rinse tank with fill-level indicator is located at the rear of the Pantera.

Everything safely stowed!

In a special compartment underneath the cab there is sufficient space for the convenient storage, for example, of the suction hose. In addition, the bowser fill port, with automatic fill-stop as standard, is located in the under-cab storage locker.

The dust proof toolbox is located under the access into the cab. Here, a hand wash tank and soap dispenser is also fitted.



The operator station: well organised and automated



The operating components of the Pantera with Comfort-Pack 2

- | | | | |
|---|---|--|---|
| 1) Ecofill connection (option) | 5) Auxiliary agitator | 9) Centralised, electric operation | 13) Control tap for induction bowl draw out/Venturi fast fill |
| 2) Self cleaning pressure filter | 6) Quick emptying | 10) Suction filter | 14) Control tap for induction bowl draw out/Ecofill |
| 3) Buttons for work lights and spray pump | 7) 3" suction port | 11) Pump (encased) | 15) Hand lance pistol for rinsing out the induction bowl |
| 4) Fresh water fill port | 8) Additional display for Comfort Pack 2 (option) | 12) Button for hydraulic lift of the induction bowl (option) | |

- ❗ “The induction bowl is just so comfortable to operate and has an excellent rinsing and agitation ring line”
(dlz magazine "Test report Pantera 4502" 02/2016)



Induction bowl and power injector

Powdery substances and large quantities of urea are dissolved quickly and safely by the induction bowl with the rinse ring and additional nozzle, and simultaneously inducted by the power injector. The extraction and cleaning from large containers can be greatly simplified by using the Ecofill connection.

High capacity pumps

The twin high-performance piston diaphragm pumps (520 l/min.) ensure that the spraying process can even be conducted at high volumes and speeds and that sufficient agitator capacity is always available.

The pump speed can be adjusted from choice within a range of 380 to 580 rpm. This enables you to drive with low revs, for example, at low application rates. The spray pump can be switched on and off at the operator station.

Canister rinsing with the aid of the induction bowl

To ensure unproblematic cleaning of spray agent canisters and to fully utilise its content, the canister is flushed using the rinse ring and additional nozzle. Of course, the closed induction bowl can also be flushed for self-cleaning. The induction bowl when closed is dust-proof. No dirt enters the system and no liquid escapes.

Bowser fill port with automatic fill stop

The bowser fill port is located conveniently in the under-cab storage locker alongside where the suction hose can also be stored. Thanks to the automatic fill stop, any unintentional overfilling of the main spray tank, either via the suction hose or through the bowser fill port, can be prevented. This position for the bowser fill port offers the possibility of filling the sprayer, with either pre-mixed spray chemical or liquid fertiliser, on the headland without having the need to fold the boom in.



- ✔ Bowser fill port in the under-cab storage locker with automatic fill stop

Thought out in detail

Comfort-Pack options

With the Comfort-Pack, the Pantera features professional equipment for the automation of the spray agent liquid circuit. Control of the most important functions of the spray agent circuit (filling, agitator intensity and cleaning) are all carried out remotely via the terminal.

In this way the desired filling amount can be pre-selected and the filling procedure is automatically isolated. The "Rührmatic" system provides a continuous, fill-level dependent adaptation of the agitation intensity. When drawing in fresh water, the agitators are automatically shut

off. For the treatment of the remaining area, the targeted addition of fresh water is possible. With the flushing function, the booms can be cleaned without changing the original concentration. The automatic cleaning provides a reliable dilution of residual amounts and internal tank cleaning.

In addition to this automatic control you can also actuate all the functions by hand on the operator station. Alternatively, as an option, a bowser fill port is available.



Comfort-Pack 2

This new option, with additional fresh water pump for more comfort when filling and cleaning, is quicker, washes out even cleaner and yet is still simple.

All functions of the Comfort-Pack 2 are operated via the AMADRIVE.

An additional display at the operator station helps input the desired fill levels from ground level.

The benefits of Comfort-Pack 2:

- ✔ Completely automatic cleaning procedure with continuous internal cleaning.
- ✔ Just couple the suction hose once and both the spray agent tank and the fresh water tank are automatically filled.
- ✔ Fresh water is immediately available when canister flushing and for the external wash down kit which are thus always ready to start.

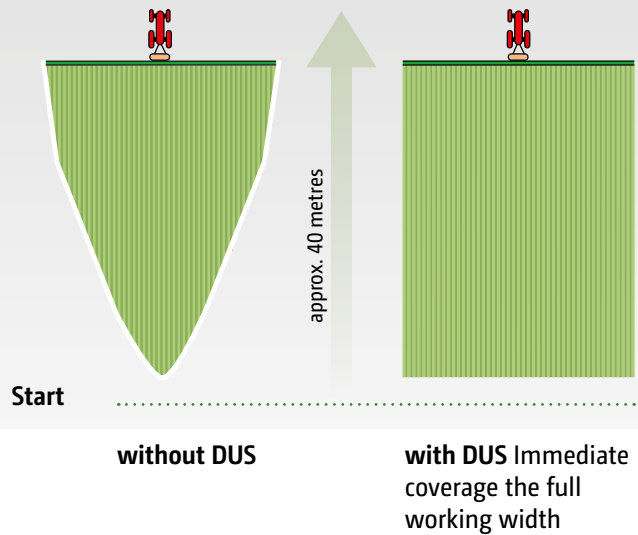

The DUS pressure recirculation system – proven more than 10,000 times

The AMAZONE DUS pressure recirculation system guarantees the safe circulation within the entire system. When starting the spraying operation all the hoses including the spray lines are filled under pressure in the reverse direction with the mixed spray agent. This means the spray lines are always full and immediately ready to use over the entire working width. There is no waiting on the headland.

Every time individual part-width sections are shut off, during the turning operation and during transport, the spray liquid circulates continually thanks to the pressure recirculation system. This reliably prevents deposits, blockages or segregation in the spray lines.

The concentration of the spray agent always remains constant right up to the nozzles, so the start of spraying is carried out without any problems after, for example, a change of ingredients.

During the cleaning operation, fresh water flushes the spray lines out right up to the nozzles without any spraying being necessary. During this cleaning procedure the concentrated spray liquid is returned back to tank via the pressure recirculation system leaving the spray lines clean.

Your benefits:

- ✔ Direct electric control of the nozzle body
- ✔ Every nozzle body is integrated in the DUS pressure recirculation system!

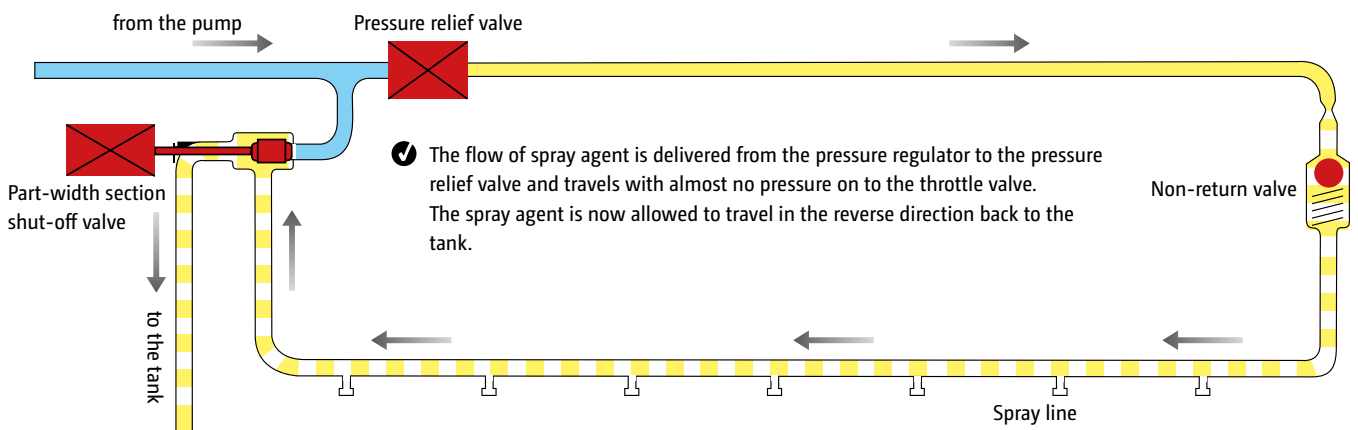

❗ “Thanks to Comfort-Pack II, the induction of the spray agent is carried out completely and conveniently from down at ground level”
 (dlz magazine "Test report Pantera 4502" 02/2016)

Super-L2 boom

Superbly light and superbly compact due to the special AMAZONE aircraft wing design

Pantera – with clever intelligence AMAZONE booms in profile design

At the same time: light – robust – compact – durable
On the Pantera self-propelled sprayer the Super-L2 boom proves its extraordinary qualities.

Thanks to the special AMAZONE profile design, it is not only light and extremely sturdy but also very compact. Even with the maximum boom width of 40 m the transport width is still only 2.55 m. In the transport position the booms are located behind the cab. That means: No obstruction of the driver's view and no dripping liquid within reach of the cab.

Premium boom quality ensures a long service life even when working at very high work rates.

Your benefits:

- ✔ Tried and tested modular system of the Super-L2 boom ranging from 24 m to 40 m, extremely sturdy and durable
- ✔ Wide height adjustment range of 0.50 m to 2.50 m
- ✔ Central pendulum adjustment and hydraulic tilt adjustment of the boom provide smooth boom travel even at high speeds
- ✔ Standard: Profi-fold 1 - independent, one sided folding that is flexible in all working widths
- ✔ Option: tip angling (Profi-fold 2)
- ✔ Option: DistanceControl for automatic boom ride height



✔ Compact transport dimensions:

- 2.55 m wide
- 3.80 m high

✔ “The four-fold boom neatly lies tight to the tank.”

(profi 11/2011)



A pivot joint that lasts!

Stainless (VA) steel hydraulic fittings

The hydraulic fittings are made from high-grade steel for a longer service life and an improved resale value.

**Super-L2 boom working widths:
from 21 to 40 metres**

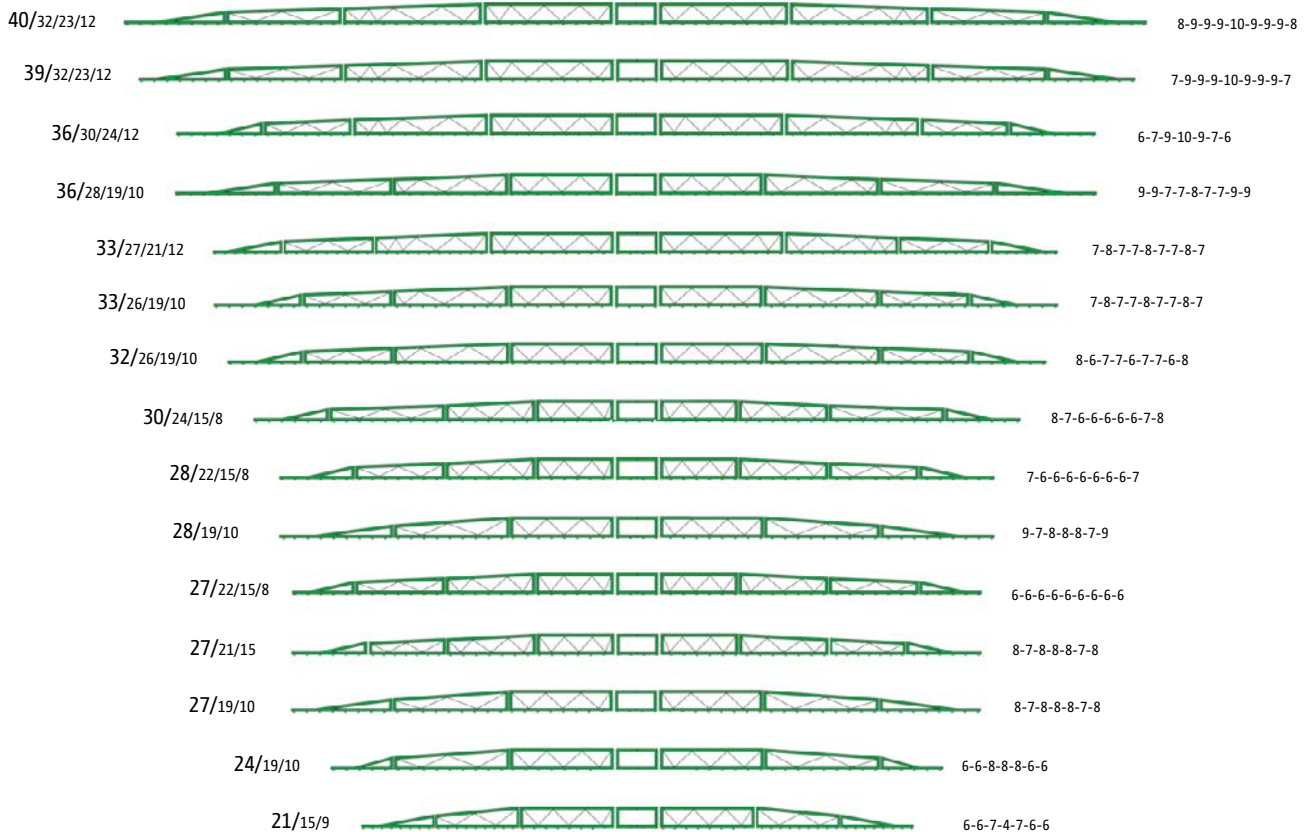

Number of nozzles / part-width sections
Other layouts possible



Flexible, quick and precise

Even better with Profi-fold!

Profi-fold – flexible and comfortable.

All hydraulic functions can be easily and reliably controlled via AMATRON 3 in the tractor cab. The multi-function joystick makes handling especially comfortable.

Profi-fold 1:

Height adjustment, folding in and out, independent, one side folding at reduced speeds (max. 6 km/h), boom width reduction, and tilt adjustment.

Profi-fold 2:

In addition with variable geometry, individual boom tip angling.

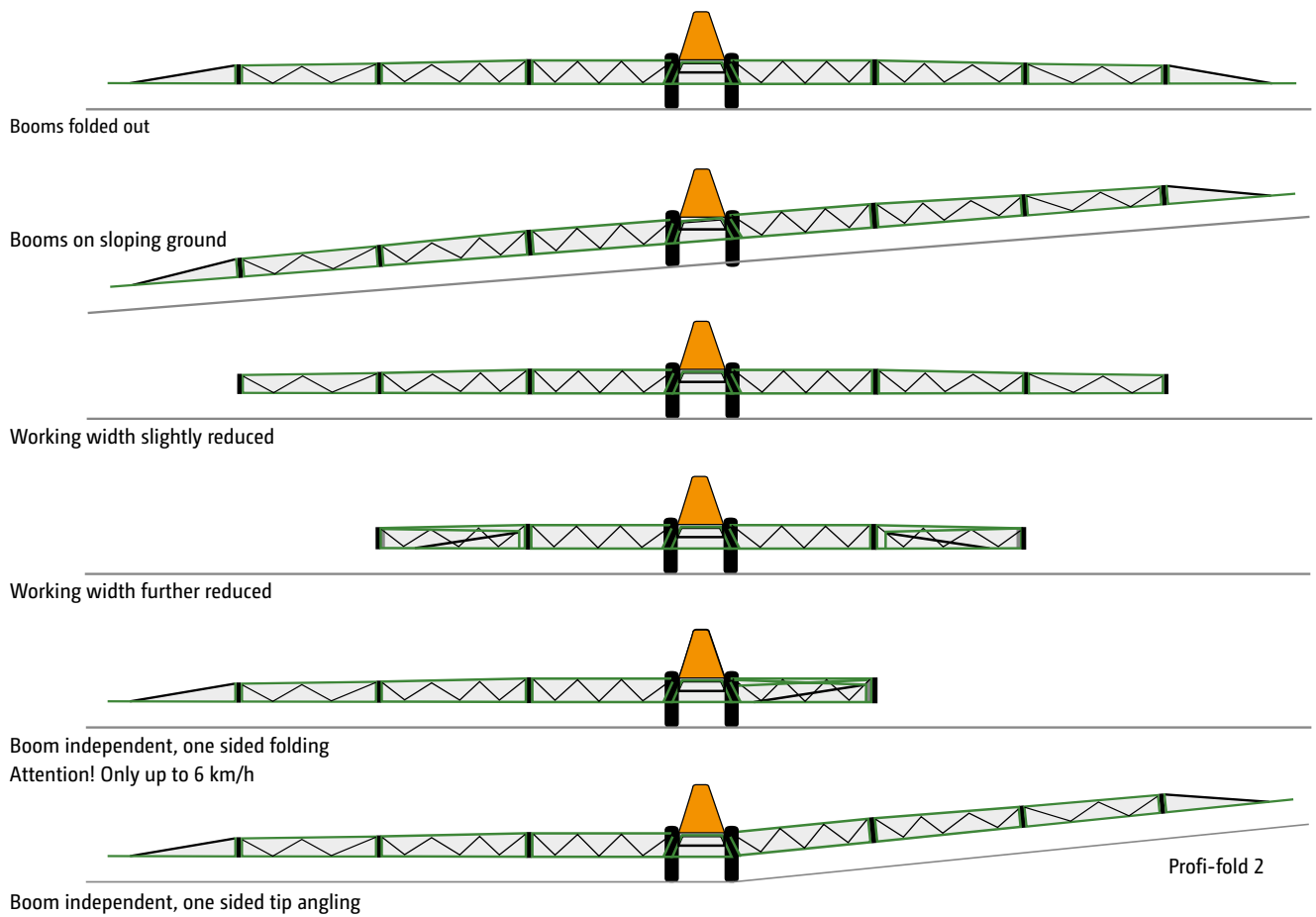

The 4-fold shock damping suspension on the Super-L2 boom

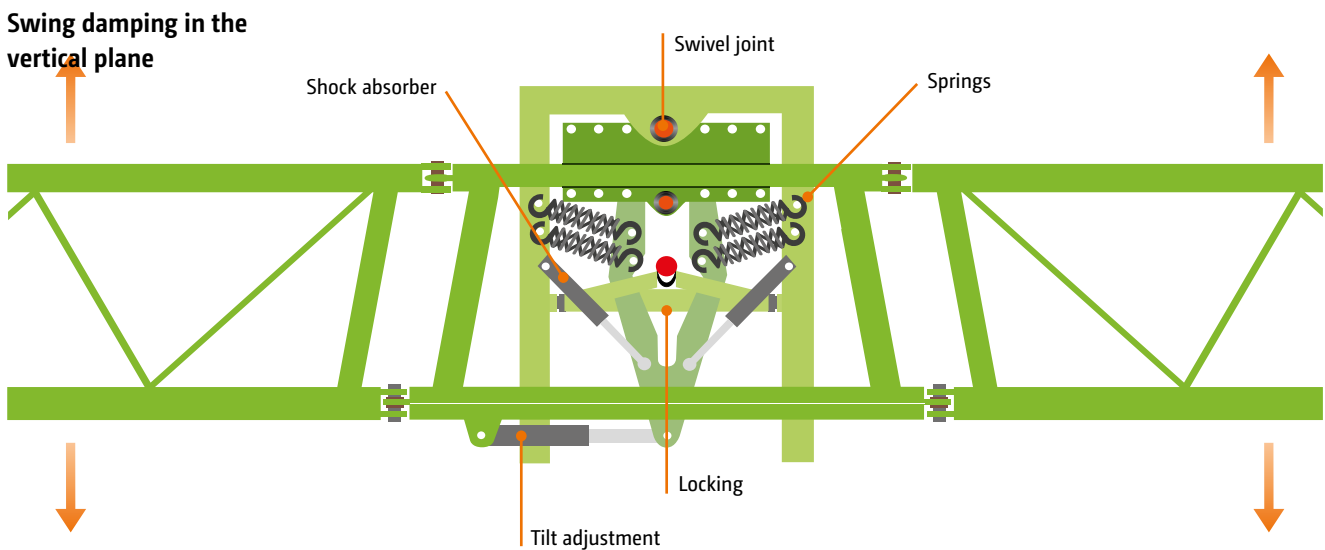
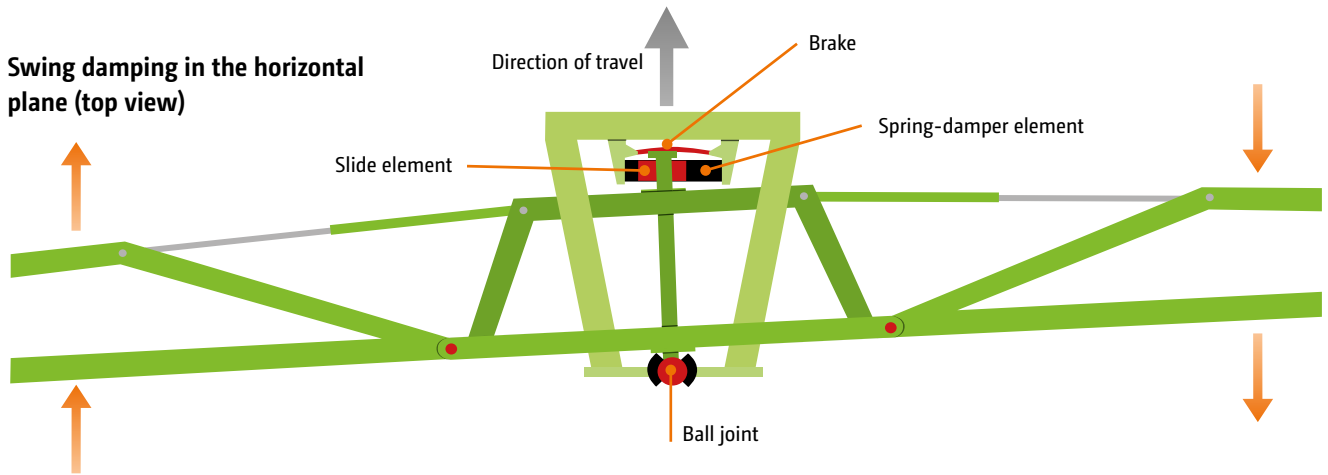

❗ “The booms can be folded in either side independently or both sides together. This means that a variety of tramline widths can be covered making it the ideal solution for contractors”
 (dlz “Test report Pantera 4502” 2/2016)

✔ Reduced boom movement even at high operational speeds

Super-L2 boom

* Reduction via manually-actuated folding joints



Boom guidance management

AutoLift or DistanceControl? It's your choice!

With the automatic AutoLift boom lift (standard execution) the boom is raised into the desired height every time the boom is switched off. During spraying it lowers again to the target height.

Alternatively with DistanceControl automatic boom guidance, it is the perfect special option available. With the aid of DistanceControl, the boom follows the crop canopy, where it is automatically raised at the headland and further regulated for height and tilt.

DistanceControl enables either the automatic height and tilt regulation, or tip angling and tilt adjustment in conjunction with Profi-fold 2.

The driver concentrates on the correct spray application; the computer concentrates on the optimum boom ride!



The boundary nozzle switching – four options to suit all needs

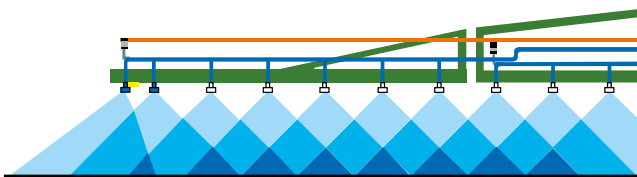

Additional nozzle switching

In order to extend the normal working width, an asymmetrical nozzle can also be switched on. This is particularly useful if the distances between tramlines are not precise enough.

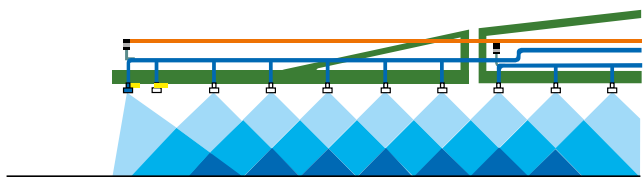

Boundary nozzle switching

For precision border spraying between two sensitive crops, the boundary nozzles can be used to make sure the spray pattern is accurately defined.

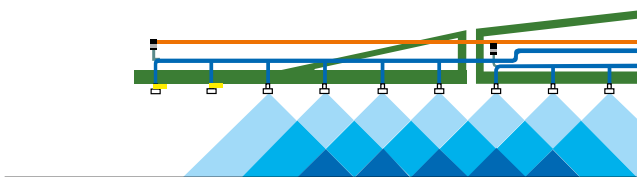

End nozzle switching

If a one metre buffer zone around the edge of the field needs to remain unsprayed due to distance constraints, end nozzle switching can be used.

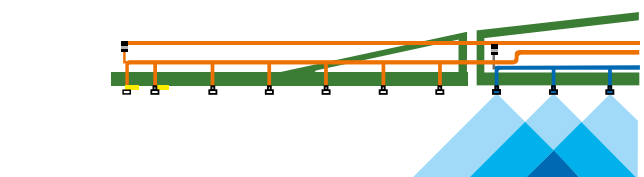

Outer part-width section switched off - DUS is active

Direct electric control of the boundary nozzles. Every nozzle body is integrated in the DUS circulation!

DistanceControl/DistanceControl plus

With 2 sensors or with 4 sensors

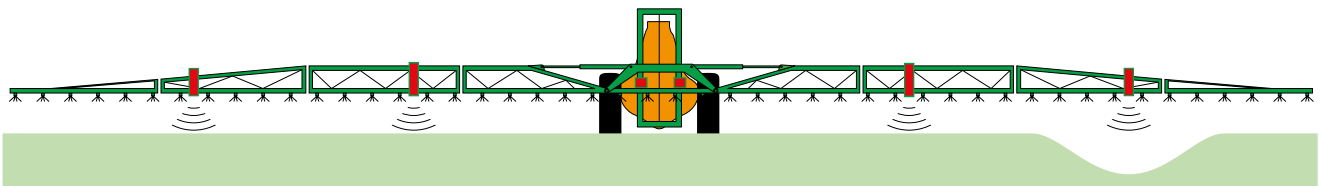

The fully automatic DistanceControl boom guidance can be equipped with 2 sensors or, when specified in the version DistanceControl plus, with 4 sensors.

In most cases, with the aid of DistanceControl, the boom follows the target surface at an optimum height and angle so that the correct distance between the nozzle and the target surface is maintained. Under particularly difficult conditions, however, two sensors are not sufficient as, especially in heavily differing crop heights, or in areas with

partially lodged corn, it can happen that the boom dips into the crop. In this case the optional DistanceControl plus with its four sensors will help prevent this.

The four sensors are connected electrically in parallel and it is always the sensor that is closest to the target surface that is actuated. In this way the optimum boom guidance across the surface of the crop, even under the most difficult of conditions, is ensured.

DistanceControl when equipped with two sensors: measuring to the crop

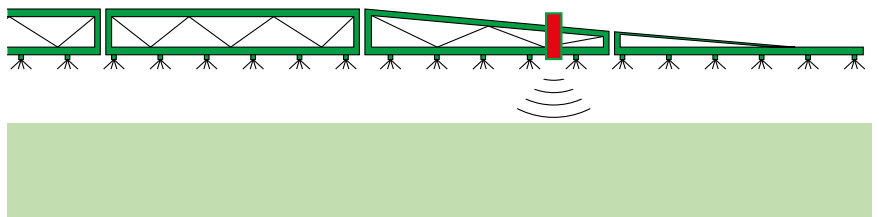

DistanceControl when equipped with two sensors: The boom can dip into the crop, for example, where there is lodged corn

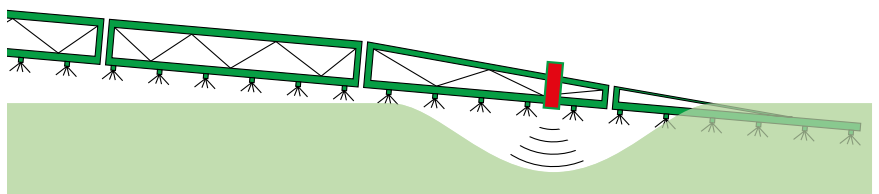

DistanceControl plus: offers the remedy in those more difficult conditions with its four sensors

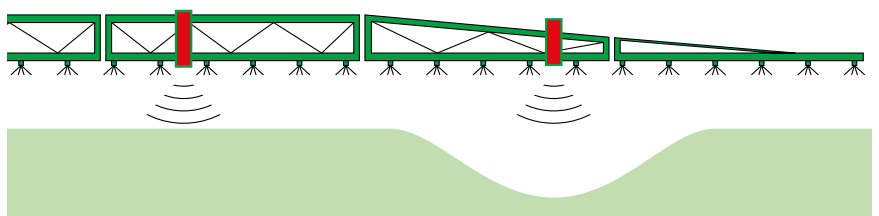

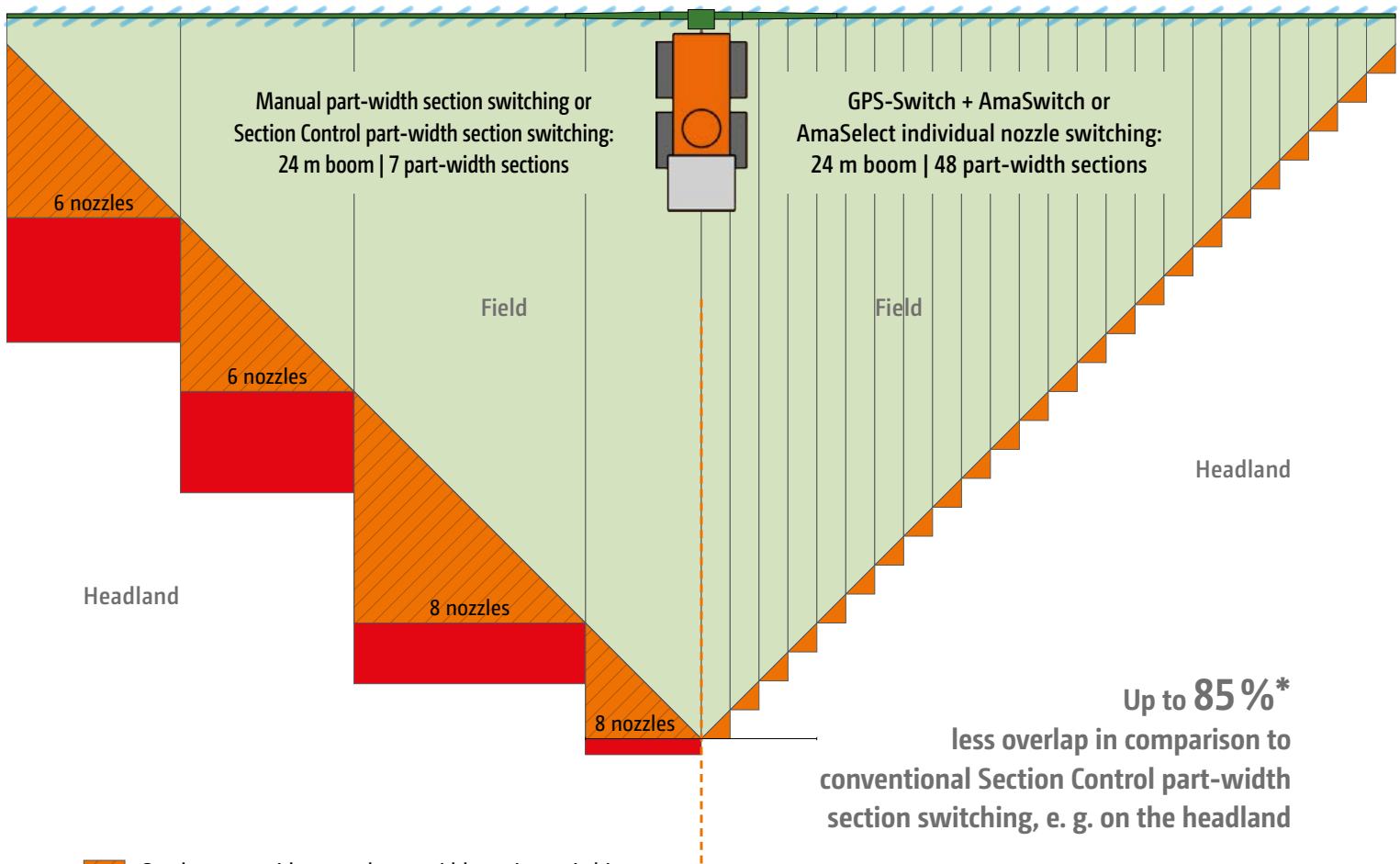

AmaSwitch and AmaSelect individual nozzle switching

Example: 24 m boom width (6-6-8-8-8-6-6 = 48 nozzles)



Up to **85%***
less overlap in comparison to conventional Section Control part-width section switching, e. g. on the headland

-  Overlap zone with manual part-width section switching
-  Overlap zone with Section Control part-width section switching

-  Overlap zone with 50 cm GPS part-width sections

GPS-Switch
Automatic headland and part-width section switching

5%*

Saving of crop protection agent



AmaSwitch
electric individual nozzle switching
or
AmaSelect

5%*

Additional saving of crop protection agent

* Savings are dependent on field structure, boom width and the number of part-width sections

Exact switching in 50 cm part-width sections

The decisive benefit of this individual nozzle switching is the possibility to operate with small part-width sections to be even more precise in wedge-shaped areas, short work and on the headland. The amount of overlap is significantly reduced on the headland, for instance, by up to 85 % less when compared with conventional Section Control part-width section switching. In this way, depending on field shape, boom width and number of part-width sections, the combination of GPS-Switch and AmaSwitch results in considerable savings of spray agent compared with the usual crop protection techniques used up to now.

If AmaSwitch or AmaSelect are combined with GPS-Switch automatic headland and part width Section Control, the individual nozzles are automatically switched in 50 cm part width sections.

Including DUS pro high pressure recirculation

Standard equipment with AmaSwitch and AmaSelect includes the DUS pro high pressure recirculation system. DUS pro prevents deposits in the conical spray line and ensures an even spray agent concentration. Thanks to the pressure recirculation system, all the nozzles are ready for operation over the entire boom width. In addition, when switching off individual part-width sections and when turning or during transport, the spray agent remains in constant circulation. In this way deposits, blockages and any potential demixing in the spray lines is safely prevented.

Calculated example:

Annual average overlapping on conventional part-width sections compared with 50 cm part-width sections



The key points of this field analysis

- ✓ Average overlap with 50 cm part-width sections only 1.92 %
- ✓ Average overlap with 9 part-width sections 7%
- ✓ Short payback period for large farms due to annual saving potential
- ✓ Due to smaller field sizes, smaller farms save proportionally more
- ✓ When growing crops with a high crop protection demand (e.g. potatoes, beet), the 50 cm part-width section is particularly cost-effective

The benefits	Standard valve chest	AmaSwitch	AmaSelect
Multiple boom sections	up to 13	up to 80	up to 80
50 cm part-width sections	–	■	■
Manual nozzle switching	■	■	–
Automatic nozzle changeover and switching	–	–	■
Nozzle selection from the cab	–	–	■
Nozzles used in combination	–	–	■
High pressure recirculation (DUS pro)	–	■	■
25 cm nozzle spacing	■	–	■
Individual programming of the part-width sections (TB)	–	■	■
No need for compressed air	■	■	■
LED individual nozzle lighting	■	■	■

AmaSwitch individual nozzle switching

Automatic 50 cm part-width section switching

Even today, many crop protection sprayers in the market feature a normal part-width section valve chest. Here the classic part-width section often is 3 to 5 m wide. For manual part-width section actuation by the driver, having smaller part-width sections did not really make sense due to the accuracy of the switch points. Thanks to the automatic part-width section control via GPS-Switch, more precise switching points with even smaller part-width sections are used so that valuable crop protection agents are saved. With AmaSwitch, AMAZONE offers a simple and precise solution for the automatic part-width section switching on 50 cm part-width sections.

AmaSwitch is a cost-effective alternative for users who do not want to make electric nozzle changeover a priority but, however, want to make use of the advantages of the very precise switching in wedge-shaped fields and overlap zones thanks to the 50 cm part-width section control.

Standard equipment with AmaSwitch includes the DUS pro high pressure recirculation system and, in addition, can be equipped with LED individual nozzle lighting.

Triple nozzle body, with electric on/off switching

The technology behind AmaSwitch is based on a conventional, manually-rotated, triple nozzle body with electric individual on/off. The opening and closing is achieved via an electric valve which is fixed directly onto the nozzle body. So, in conjunction with GPS-Switch, it is possible to control the boom very precisely in 50 cm part-width sections in wedge-shaped fields and on the headland. In addition to the automatic switching using 50 cm part-width sections, it is possible to configure the amount of part-width sections from choice.



✔ AmaSwitch triple nozzle body with optional LED individual nozzle lighting

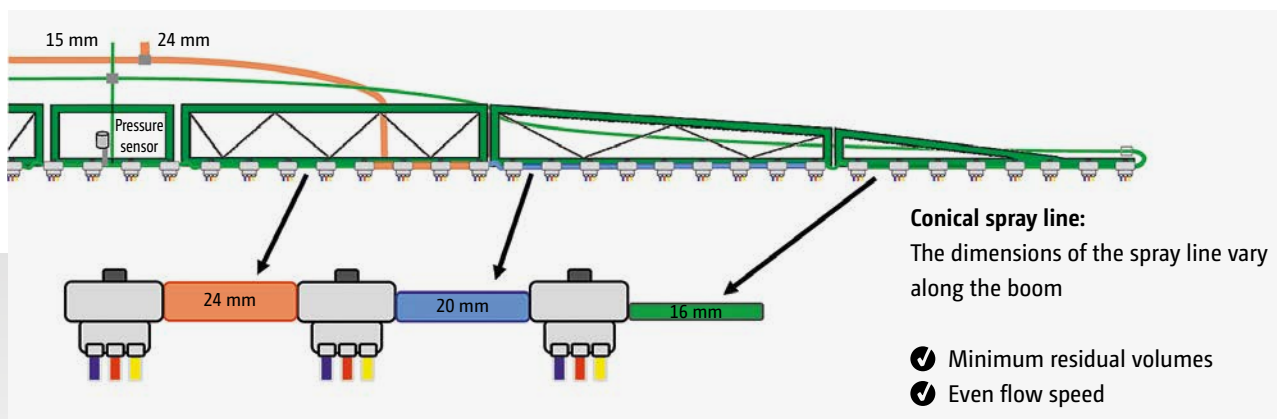

DUS pro high pressure recirculation with conical spray line on here, for example, AmaSwitch

AmaSelect individual nozzle control

The most up-to-date application technology

The AmaSelect individual nozzle control consists of a 4-fold nozzle carrier with electric on/off switching enabling, additionally, the changeover from nozzle to nozzle. In this way, the system offers in addition to the 50-cm part width section control which can be automatically switched via GPS-Switch, the electrical changeover between the four fitted nozzles via the operator terminal.

An additional possibility is the automatic changeover or switching on of a nozzle. By entering in the terminal the optimum pressure range of every individual nozzle within the 4-fold nozzle carrier, the system automatically changes over the nozzles according to these predetermined factors. This offers the possibility, for instance when leaving the optimum pressure range of a nozzle, to switch on a second nozzle or to changeover to a larger nozzle. However, if desired, any number of part-width sections can be freely configured to include any number of nozzles. Just for farmers or agricultural contractors with different tramline systems, a simple matching of the nozzle switching with the relevant working width is possible.

With 50 cm or 25 cm nozzle spacing

As an option, the AmaSelect nozzle carrier can also be equipped with an off-set kit giving 25 cm nozzle spacing. This, in conjunction with special 80° nozzles, offers the benefit of reducing the target height above crop to below 50 cm. In addition, this version can be supplemented by the HighFlow option for applications with extremely high application rates.

As standard, AmaSelect is equipped with DUS pro high pressure recirculation and LED individual nozzle lighting.

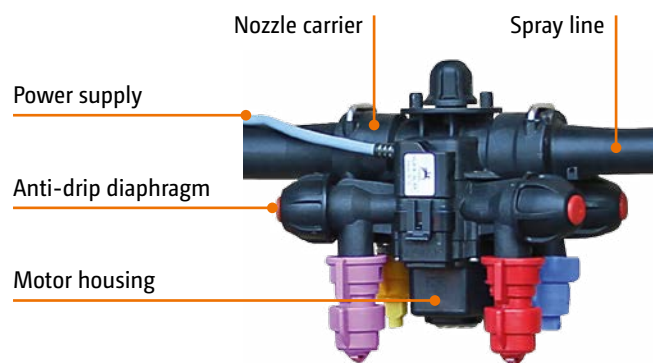

🔌 AmaSelect – components of the system

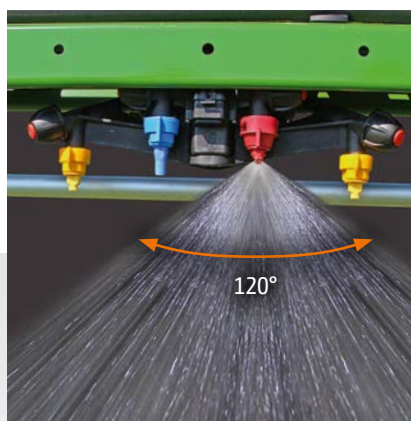
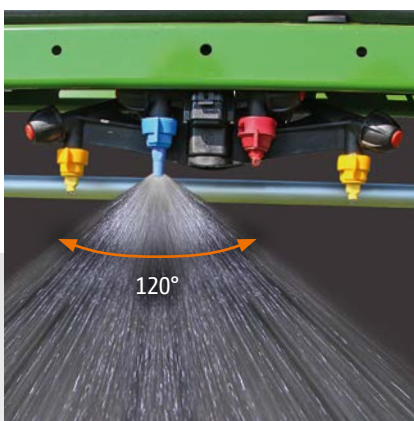

The electric AmaSelect individual nozzle switching with 4-fold nozzle carrier and either a 50 or 25 cm nozzle spacing

Cleaning management

Thought out and comfortable – the Pantera in practical operation



External wash down kit and internal cleaning

The internal cleaning system with seven rotating nozzles provides the best of cleaning performances inside the tank.

Via the spray lance on its 20 m long hose, the self-propelled sprayer can be thoroughly cleaned externally immediately after operation whilst still in the field. The high-pressure spray lance with its delivery capacity of only 17 l/min works at an operating pressure of 10 bar.

In addition, a 20 litre handwash tank with soap dispenser is supplied.

Your benefits:

- ✔ hose length
- ✔ 10 bar operating pressure
- ✔ only 17 l/min. delivery capacity





Liquid fertilisation – mature solutions for high outputs

The Pantera is especially suited for liquid fertilisation: the use of high grade plastic materials, good paintwork and the virtually exclusive use of stainless steel ensures a long life even with liquid fertiliser operation.

For coarse droplet distribution of liquid fertiliser, AMAZONE offers multi-hole nozzles (3 or 7 holes) or even FD sluice nozzles.

On request, the Super-L2 boom can be equipped with a second spray line. The staggered nozzle bodies then allow the fitting of drag hoses at a spacing of 25 cm. Drag hoses offer a risk-free late top dressing with liquid fertiliser and stainless steel weights help keep the position of the drag hoses within the crop.

Special equipment: HighFlow

To double the maximum application rates both the pumps can be switched into parallel. The HighFlow option opens up a new dimension in output.

It allows large quantities of liquid fertiliser to be applied at higher speeds.

For vegetable applications, then rates of 2,000 l/ha at 5 -6 km/h are possible.

The large rates are only possible with an additional spray line giving twice the number of nozzles, placed 25 cm apart.



The right nozzle choice

The basis for success in crop protection



Less drift also at higher wind speeds

With the air-assisted injector nozzles, crop protection agents can be applied with very little drift. They are universally usable in all crops and all classifications. Because of the coarse droplet application, these nozzles can also be used in higher wind speeds.

AMAZONE offers the agricultural sector a wide range of nozzles from Agrotop, Lechler and Teejet.

Single and multi-nozzle bodies

The nozzle bodies with integrated diaphragm non-return anti-drip valves fit up into the boom profiles reliably preventing any dripping at the nozzle. Self-adjusting bayonet fixings ensure a tool-less quick nozzle change. The triple nozzle bodies are suited to frequent nozzle changes due to different applications and crops. Nozzle protection tubes, as standard on the outer sections, or, if desired, over the entire boom working width, ensures protection for long injector nozzles and multiple nozzle bodies.





Examples

- 1) Lechler IDN 120-025
- 2) Teejet XRC 110-025
- 3) Agrotop Airmix 110-04



Everyone purchasing an AMAZONE crop protection sprayer receives, free of charge, an AMAZONE nozzle mounting tool that enables a much easier nozzle change.

Injector nozzles (ID, TTI) have a relatively coarse droplet spectrum and are particularly versatile with regard to their field of application. A pressure range of 2 to 8 bar is possible.

The split spray pattern ensures a more even deposit on the front and back of the plant and makes sense maybe, for example, in ear treatment.

If coverage quality is at the foreground of the application, the use of standard or anti-drift fine droplet nozzles, such as XR or AD, is recommended. Special care is required here due to the tendency to drift above 3 bar.

For speeds greater than 10 km/h, the TD HiSpeed nozzle with its asymmetrical spraying angle is becoming a new industry trend.

A good compromise is provided by the modern ID-K or Airmix compact injector nozzles. These have relatively little drift, but do not have too coarse a droplet spectrum and are operated at 2 to 4 bar.

Distribution of the droplet size

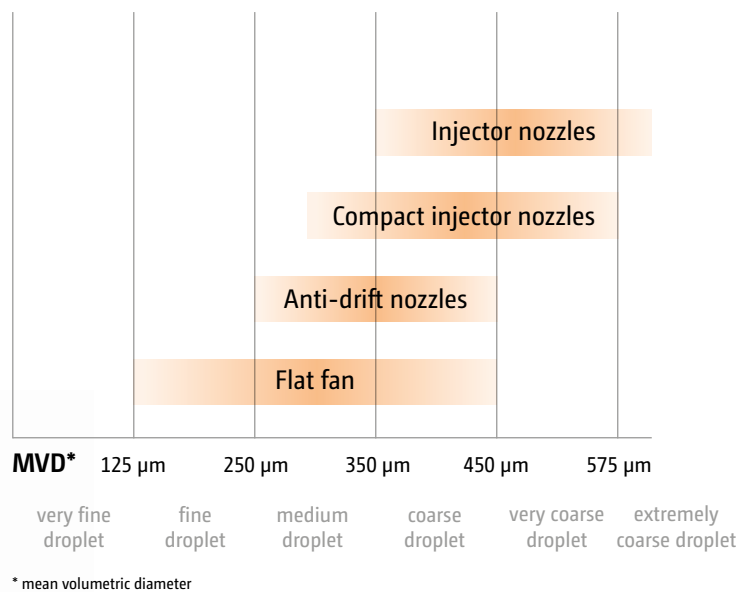

When it comes to special coverage qualities the double flat fan nozzle is an interesting alternative: the AVI Twin from Agrotop also produces droplets that are not too fine.



Standard execution: Pantera 4502



- ✔ Hydro-pneumatic suspended tandem chassis with automatic level regulation, suspension fill level and forward speed related regulated
- ✔ Infinitely-variable, automatic central track width adjustment from 1.80 m to 2.40 m (or depending on tyres up to 2.60 m)
- ✔ Hydraulic front wheel steering, 4-wheel steering and dog leg steering, steering angles matched to the operational speeds
- ✔ Headland management with automatic switch-over from front wheel to 4-wheel steering, boom lift via AutoLift
- ✔ Speed 50 km/h, infinitely variable hydrostatic individual wheel drive with traction control
- ✔ Fill level-dependent braking system
- ✔ Deutz 6-cylinder diesel engine with Common-Rail injection technology, country specific emission level 3A or 4, maximum power rating 218 HP (160 kW) in accordance to ISO 14396, exhaust gas recirculation and diesel particle filter
- ✔ ECO-Mode: fuel saving, capacity depending engine rev regulation on the road and in the field
- ✔ CLAAS Vista cab, climate control, heating, air-suspended comfort seat, adjustable steering column, CD radio with Bluetooth hands-free mobile phone connection, sun visors for front and rear windows
- ✔ Colour AMADRIVE touch-screen terminal (10.4 Inch) for vehicle operation
- ✔ Parking light, dip beam and high beam, 4-way front worklights, 4-way side worklights and 2-way side view worklights, lighting of the booms in front and three worklights on the operator terminal, filling dome and fuel tank





- ✔ Spraying pump (260 l/min delivery capacity), Agitation pump (260 l/min delivery capacity), 520 l/min delivery capacity total
- ✔ Pump speed settable in the terminal and remote control of the pump via the operator terminal.
- ✔ Suction valve with 3" suction filter (32 mesh) and filling port for fresh water tank
- ✔ Pressure chest, self-cleaning 1"1/4 pressure filter (50 mesh) and part-width section control, quick emptying
- ✔ Comfort-Pack 1 for automatic filling, fill-level dependent agitation regulation and remote control cleaning from the cab
- ✔ Super-L2 boom with spray line, pendulum compensation and Profi-fold 1
- ✔ Spray agent tank 4,500 l (actual volume 4,800 l) with agitator, fill level indicator, clear water tank 500 l
- ✔ Induction bowl, internal tank cleaning nozzles
- ✔ Electric remote control
- ✔ AmaPilot/AmaPilot+ multi-function joystick for vehicle steering and operation of the sprayer
- ✔ Cover for operator station, hand wash tank, external wash-down kit, digital external fill level indication

These are the opinions of those that use them:



Holger Thomsen
Uphusum, Germany

Contractor Holger Thomsen has operated an AMAZONE self-propelled sprayer across more than 5000 hectares per year: "As a contractor, one has to use the technology that customers do not have themselves. Therefore, for plant protection only a self-propelled sprayer is worth considering for us."

Holger Thomsen's experiences with...

...the all-wheel steer of the self-propelled sprayer: "When turning at the headland, we only leave two tracks with the self-propelled sprayer, that means, we do not do so much damage in growing crops."...the hydro-pneumatically suspended tandem chassis of the self-propelled sprayer: "It compensates for the ground undulations better. This results in a very even boom ride."

...the ground clearance of 1.10 m: "It plays a part, for example, when treating rape at flowering, because the plants are hardly damaged."

...the drive-line of the self-propelled sprayer: "With the infinitely variable hydrostatic drive-line and the 218 HP engine, the self-propelled sprayer is well equipped to maintain speeds on the road but also in the field without any problem. Engine and drive-line are suited for the size of this machine."

...the hydraulically adjustable track width of the self-propelled sprayer: "It proves to be of advantage, for example in spring, for herbicide treatment in maize. If, in the future, some customers want to convert their maize crops to narrow spacing, such an easy to handle track width adjustment is actually absolutely essential."

AMAZONE Service – always in the vicinity

Your satisfaction is our challenge



**Original
AMAZONE**

2. Auflage | 2nd edition
2e édition | 2-е издание

Verschleißteilkatalog
für Landtechnik und Kommunaltechnik

Wearing parts catalogue
for agricultural machinery and groundcare products

Catalogue pièces d'usure
pour machines agricoles et gamme espaces verts

Каталог изнашиваемых деталей
для сельскохозяйственной и коммунальной техники



**Choose the Original
Choose Success!**

VDMA campaign:
Pro-Original



The satisfaction of our customers is the most important objective

For this we rely on our competent sales partners. Also for service queries, they are the reliable contact for farmers and agricultural contractors. Due to continuous training, our sales partners and service technicians are always up to date when it comes to looking after this state of the art technology.

We provide you with a first-class spareparts service

The central spareparts store in our headquarters at Hasbergen-Gaste forms the basis of our world-wide spare parts logistics. This ensures the optimum availability of spareparts, even for older machines.

Parts, are available in our central spareparts store in Hasbergen-Gaste and which have been ordered up until 17 hours, are dispatched the same day. 34,000 different spareparts and wearing metal are held in our ultra-modern stores system. Daily, up to 800 orders are dispatched to our customers.

Better to choose the original, right from the beginning

Your equipment is exposed to the most arduous of demands. The quality of AMAZONE spareparts and wearing metal offers you the reliability and safety you need for efficient soil tillage, precise sowing, professional fertilisation and successful crop protection.

Only original spareparts and wearing metal is perfectly matched to AMAZONE machinery in their functionality and durability. This ensures the optimum operational performance. Original parts at a fair price pay off in the end.

Therefore, make your decision the original!

The advantages of original spareparts and wearing metal

- ✔ Quality and reliability
- ✔ Innovation and efficiency
- ✔ Immediate availability
- ✔ High resale value of the used machine

AMAZONE "E-Learning" – the new way of driver training via a PC

Via the Internet "E-Learning" portal, AMAZONE has extended its service offering on its homepage www.amazone.de/e-learning with a very useful function. "E-Learning" offers interactive driver training, which enables the driver to practice the operation of complex machinery on his own, both online and offline, via a PC or tablet. The new service offers drivers the possibility to get acquainted with a new machine prior to its initial operation. However, experienced drivers can also refresh their knowledge enabling them to utilise better still the full potential of their machinery.

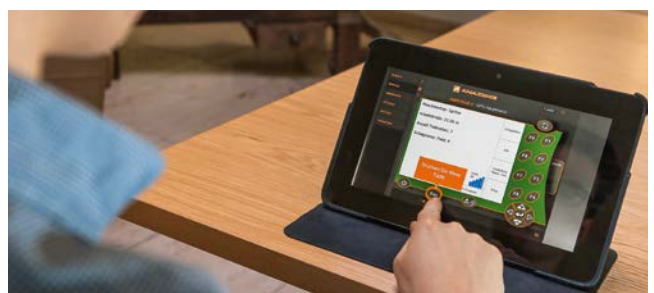



Tyres

Dimensions	Pantera	Pantera-W	Pantera-H	Load index	permissible load carrying capacity at 50 km/h / at a pressure of	Cross-sectional width in mm	Outer diameter in mm
300/95 R52	X	X	X	159A8 / 157B	4,200 kg/4.8 bar	310	1,890
320/90 R54	X		X	155A8 / 155B	3,875 kg/3.6 bar	319	1,948
340/85 R48	X	X		159A8 / 156D	4,200 kg/4.4 bar	345	1,805
380/90 R46	X	X	X	168D	5,600 kg/2.5 bar	389	1,842
380/90 R46	X	X	X	173D	6,500 kg/2.2 bar	383	1,842
380/90 R50	X	X	X	158A8 / 158B	4,250 kg/3.3 bar	380	1,954
380/90 R50	X	X	X	175D	6,900 kg/3.3 bar	385	1,947
480/80 R42	X	X		156A8 / 156B	4,000 kg/2.4 bar	494	1,858
480/80 R46	X		X	158A8 / 158B	4,250 kg/2.0 bar	499	1,948
480/80 R46	X	X	X	177D	7,300 kg/3.6 bar	480	1,948
520/85 R38	X	X		155A8 / 155B	3,875 kg/1.6 bar	540	1,838
520/85 R42	X	X	X	157A8 / 157B	4,125 kg/1.6 bar	516	1,951
620/70 R38	X			170A8 / 170B	6,000 kg/1.6 bar	608	1,864
650/65 R38	X			157D	4,330 kg/1.4 bar	618	1,828
710/60 R38	X			160D	4,500 kg/1.0 bar	712	1,814

Illustrations, content and technical data are not binding! Deviations of technical data are possible depending on the equipment. The illustrations may deviate from the requirements for local road traffic regulations.

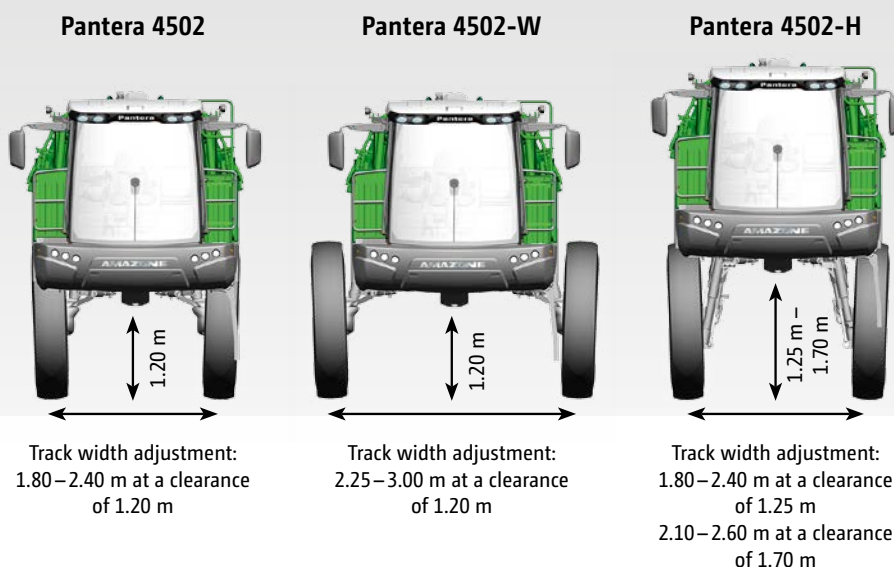

Technical data: Pantera 4502

Model	Pantera 4502	Pantera 4502-W	Pantera 4502-H
Nominal volume (l)	4,500		
Actual volume (l)	4,800		
Fresh water rinse tank (l)	500		
Working width (m)	21 – 40		
Fuel tank capacity (l)	230		
Max. working speed (km/h)	20		
Transport speed (km/h)	up to 50		
Length (m) (Transport position, plus external wash down kit)	8.60		
Transport width (mm)	2.55	2.75	2.55
Spraying height min./max. (m)	0.50 – 2.50 with lift module 0.50 – 3.20		0.50 – 3.00 with lift module 0.50 – 3.70
No. of part-width sections (min./max.)	7 – 13		
No. of sections with individual nozzle switching: Amaswitch or AmaSelect	up to 80		
Unladen weight (kg)	9,600	9,950	10,500
Max. total weight (kg)	15.800 (depending on tyres)		
Delivery capacity pump (l/min)	520		
Turning circle, all-wheel steer (m)	4.50		
Track width (mm)	1.80 – 2.40	2.25 – 3.00	1.80 – 2.40 at 1.25 2.10 – 2.60 at 1.70
Ground clearance (m)	1.20	1.20	1.25 / 1.70 in the lower/upper working position
Engine power	max. 160 kW (218 HP) (Data according to ISO TR 14396)		

Illustrations, content and technical data are not binding! Deviations of technical data are possible depending on the equipment. The illustrations may deviate from the requirements for local road traffic regulations.



AMAZONE



AMAZONEN-WERKE H. DREYER GmbH & Co. KG

P. O. Box 51 · D-49202 Hasbergen-Gaste/Germany

Phone: +49 (0)5405 501-0 · Fax: +49 (0)5405 501-193