



COMPACT EXCAVATORS
E16 FACELIFT



One Tough Animal™

E16 FACELIFT – SPECIFICATIONS

Weights

Operating weight (MARK)	1615 kg
Additional weight for cab with heating	129 kg
Additional weight for steel tracks	53 kg
Ground pressure with rubber tracks	28.60 kPa

Engine

Make / model	Kubota / D722-E2B-BCZ-5
Fuel	Diesel
Number of cylinders	3
Displacement	0.72 L
Maximum net torque at 1400 RPM (SAE J1995)	42.2 Nm

Performance

Digging force, dipperstick (ISO 6015)	9560 N
Digging force, bucket (ISO 6015)	16640 N
Drawbar pull	20029 N
Travel speed, low range	2.9 km/h
Travel speed, high range	4.8 km/h

Hydraulic System

Pump type	Dual piston pump with gear pump
Pump capacity	41.30 L/min
Pump 1 capacity at 2500 RPM	11.25 L/min
Pump 2 and 3 capacity at 2500 RPM	15.00 L/min
Auxiliary flow	30.00 L/min
Auxiliary relief	231.0 bar
Boom port relief base and rod end	210.0 - 250.0 bar

Slew System

Boom swing, left	80°
Boom swing, right	60°
Slew rate	8.1 RPM

Fluid Capacities

Cooling system	5.70 L
Engine lubrication plus oil filter	3.50 L
Fuel reservoir	23.80 L
Hydraulic system	21.50 L

Environmental

Noise level LpA(EU Directive 2000/14/EC)	78 dB(A)
Noise level LWA(EU Directive 2000/14/EC)	92 dB(A)

Standard Features

Hydraulically retractable undercarriage from 1330 mm to 980 mm	Retractable seat belt
980 mm dozer blade with two 190 mm blade extensions	Spark arrester muffler
230 mm rubber track	TOPS/ROPS* canopy ¹
Double acting auxiliary hydraulics with quick couplers	Two-speed travel
Control console locks	Work lights
Horn	Long blade
Hydraulic joystick controls	Warranty: 12 months, 2000 hours (whichever occurs first)

1. Roll Over Protective Structure (ROPS) – Meets requirements of ISO 3471. Tip Over Protective Structure (TOPS) – Meets requirements of ISO 12117.

Working Range

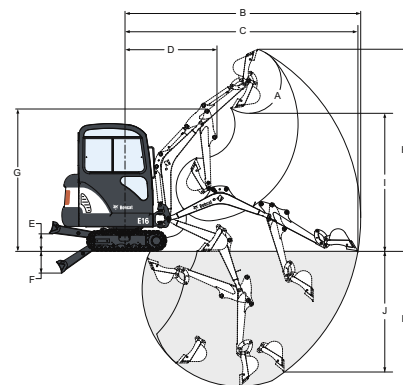

(A)	196°	(G)	2564.0 mm
(B)	4146.0 mm	(H)	3616.0 mm
(C)	4101.0 mm	(H*)	3743.0 mm
(C*)	4276.0 mm	(I)	2529.0 mm
(D)	1576.0 mm	(I*)	2656.0 mm
(D*)	1586.0 mm	(J)	2139.0 mm
(E)	308.0 mm	(K)	2422.0 mm
(F)	368.0 mm	(K*)	2602.0 mm

Dimensions

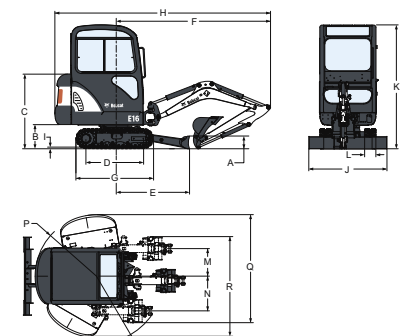

(A)	210.0 mm	(J)	980.0 mm
(B)	435.0 mm	(K)	2171.0 mm
(C)	1314.0 mm	(L)	230.0 mm
(D)	1114.0 mm	(M)	480.0 mm
(E)	1257.0 mm	(N)	605.0 mm
(F)	2856.0 mm	(O)	1192.0 mm
(G)	1472.0 mm	(P)	1086.0 mm
(H)	3925.0 mm	(Q)	1873.0 mm
(H*)	3904.0 mm	(R)	1722.0 mm
(I)	23.0 mm		

Options

TOPS/ROPS cab with heater	Suspension seat
Heavy duty radio	Four point tie down
Auxiliary hydraulic line on arm	Blade extension pads
Long dipperstick	Steel tracks
Keyless start	Travel motion alarm

Specifications and design are subject to change without notice. Pictures of Bobcat products may show other than standard equipment.



Bobcat®

www.bobcat.eu