



ATTACHMENTS
DUMPING HOPPER



One Tough Animal™

DUMPING HOPPER – SPECIFICATIONS

Main features

- The Bob-Tach™ system allows the dumping hopper to tip forward and empty itself simply by raising the Bobcat® loader's lift arm and rolling out the Bob-Tach™
- The dumping hopper's caster wheel design with flotation tires accommodates uneven ground conditions
- Inside surfaces are flat and smooth to prevent material from sticking
- The bottom plate has pre-drilled holes to evacuate rainwater

Applications

- Construction
- Renovation
- Demolition
- Landscaping
- Municipalities
- Golf courses and Resort Hotels

	Item number	Compatible with loader
Dumping Hopper Model 10	6727275	S70, S100, T110
Dumping Hopper Model 25	6717597	S130, S150, S160, S175, S185, S205, S220, S250, S300, S330, S630, S650, S770, S850, A300, A770, T140, T190, T250, T300, T320, T650, T770, T870

Weights and dimensions

	Operating weight (kg)	Shipping weight (kg)	Overall Width (C) (mm)	Overall Height (B) (mm)	Overall Length (A) (mm)
Dumping Hopper Model 10	273	302	914	1016	2032
Dumping Hopper Model 25	540	540	2133	1016	2083

Characteristics and performance

	Capacity Struck (m³)	Capacity Heaped (m³)
Dumping Hopper Model 10	0.73	0.84
Dumping Hopper Model 25	1.93	2.45

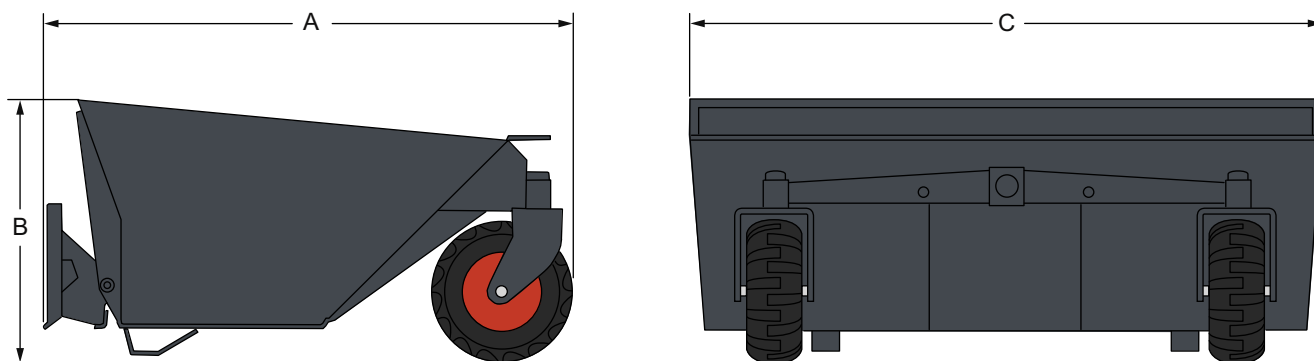

Specifications and design are subject to change without notice. Pictures of Bobcat products may show other than standard equipment.



www.bobcat.eu