



For Earth, For Life  
**Kubota**

**L2**

**KUBOTA DIESEL TRACTORS**  
**L2351/L2421/L2501/L2602**

Tractors built for premium efficiency, comfort and versatility.



# Maximum productivity and c from a class-leading range



Model	L2351	L2421	L2501	L2602
Engine gross power* (kW/PS)	27.3/57.1	33.5 / 45.5	36.5 / 49.6	45.8/62.3
No. of cylinders	3	4	4	4
Total displacement	1826	2197	2434	2424
HST 4WD		•	•	•
GST			•	
FST (4WD)	•	•	•	

# comfort

For daily, demanding tasks you need a tractor that won't let you down. The new Kubota L2 Series offers an unbeatable package of class-leading features to make your day easier and more productive.



### Responsive control

The L2 Series includes a choice of transmissions including HST Plus for automatic hydro dual-speed control – complete with a load sensing feature. Plus, Kubota's Glideshift for clutchless shifting on the move or economical Fully Synchronised Transmission (FST).



### Clean power

A choice of four Kubota diesel engines (ranging in power from 35–60 HP) deliver class-leading performance, cleaner emissions and outstanding fuel economy.



### Extremely comfortable

The L2 Series feature an integrated, ergonomically designed cab that's spacious and comfortable with simple, easy to use controls and excellent all-round visibility.



### Superior productivity

Kubota's powerful 3-point linkage provides effortless implement operation and up to 1750kg lift capacity\*. Twin auxiliary valves are standard, along with an independent live rear PTO system that can engage/disengage on the move.



### Exceptionally efficient

The highly manoeuvrable L2 Series includes power steering, 4WD as standard. Kubota designed front loaders are available to match performance to ensure precise control and easy operation.



# All the **power, response** and **p**

**Choose from three transmission options to make the most of the power generated by Kubota's extraordinarily efficient diesel engines.**



## **THE POWER TO DELIVER**

Kubota's Three Vortex Combustion System (E-TVCS) allows for increased airflow into the combustion chamber to produce greater power, efficiency and cleaner emissions. It also generates less noise and vibration, adheres to the EC Emission Test (97/68/EC) and meets Stage III A European emissions regulations for 37kW engines or above (L2501).

L2602 model features a Kubota Common Rail direct injection engine which delivers greater fuel savings and lower emissions while maintaining a high level of power and torque. Its combination of the Diesel Particulate Filter (DPF) Muffler and Exhaust Gas Recirculation system (EGR) reduces emissions to make the engines compliant with the Tier IV emission regulation.



# productivity you want



## CHOICE OF TRANSMISSION



### FST Fully Synchronised Main and Shuttle Transmission

Kubota's economical FST smoothly delivers 16 forward and 16 reverse gears (inc. creep speeds) on the move.



### GST Glide Shift Transmission

Kubota's exclusive, highly responsive GST provides 24 forward and 16 reverse gears (inc. creep speeds) with clutchless operation. The electronically controlled hydraulic system also enables you to shift on the go.



### HST Plus Hydrostatic Transmission

Automated control of both the HST pump and motor give you optimal performance, regardless of the task, working conditions, or operator expertise. In addition, HST includes a highly responsive hydraulic servo mechanism that decreases the amount of pressure required to depress the HST pedal.



## PTO and hydraulics

### Live-independent PTO

The hydraulically activated Live-independent PTO clutch enables the PTO to be independently engaged/disengaged while the tractor is moving. A Neutral/Auto Shut-off system and protective flip-up shields are included for a full upgrade in total PTO safety and productivity.

### Deluxe 3-Point Hitch

Kubota's powerful 3-point hitch enables the use of a wide range of implements. It comes with a standard quick hitch that is positioned on the tip of the lower links so that tools can be attached quickly and easily.



## HST Plus Advanced technology for efficient operation

Kubota's HST Plus gives optimal control and easy operation of both the hydraulic pump and the drive motor. By regulating the pump swash plate and adjusting the motor swash plate between two stages, you maximise the efficiency of HST Plus whether you prefer manual or automatic control.

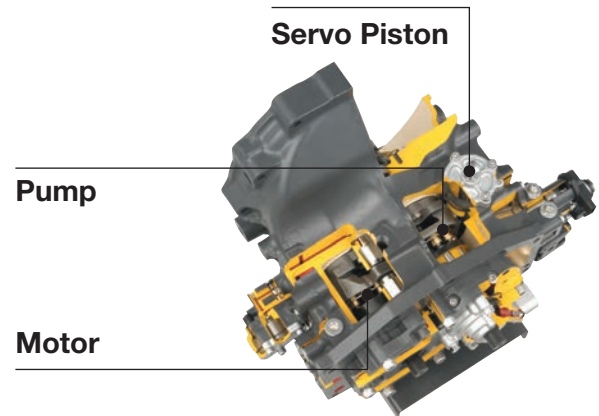

### 6 Speed Hydro Dual Speed (H-DS) Hi-Lo Function

Already featuring 3 range shift speeds, Kubota's HST Plus includes a lever to shift between high and low speeds in each range, expanding your options to six total speeds. Once your preferred range shift speed is set, you can easily shift the H-DS between the high and low speeds while moving. With a simple touch of the Mode Selection button, you can activate the Auto H-DS for automatic Hi/Lo shifting.



### Auto Throttle Advance

The new Auto Throttle Advance feature links the HST pedal and the engine throttle, synchronising tractor speed and engine revolution.

This greatly simplifies tractor operation and helps reduce fuel consumption.

Now, all you need to do to control tractor speed and engine revolutions is depress the HST pedal.

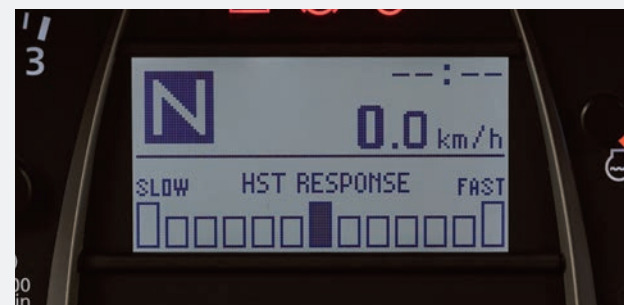

### HST Response Control

The HST response speed can be adjusted with a simple touch of a button. If your task requires a quick response, you can select the FAST setting. This setting is ideal for use during loader-related chores. If the job at hand needs a more gradual response, as used for turf work, select SLOW.

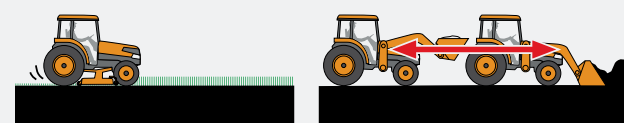

Gradual response

Quick response

### Load Sensing

The L2 Series boasts a revolutionary Load Sensing feature that, if it detects a drop in engine RPM, will automatically regulate HST pump and motor activity.

With three modes to choose from, transmission operation can be adjusted to accommodate your immediate needs. Each consecutive press of the button will select the next mode, from Mode 1 to Mode 3, and back again.



Mode	Stall Guard Plus*	Auto H-DS
Mode 1	-	-
Mode 2	•	-
Mode 3	•	•

\*When the engine is started, the tractor will remain in the same mode it was in during the previous engine shut-off.

# A new standard in comfort and safety

A comfortable, safe, ergonomically designed cab means operators can be more efficient for longer.



## Integrated Cab

Designed for comfort and to enable great productivity, we've introduced lots of glazing to minimize blind spots for a wider view. Even the doors open more widely for easier cabin entry and exit. Other benefits include a deluxe suspension seat, more legroom, plenty of headroom and generous storage spaces. The ergonomically designed cab features an intuitive, easy-to-use, large control panel for easy access to all operational and hydraulic controls and levers.

## Air Conditioning with Internal/External Air Ventilation

Switch between internal recirculation or external air ventilation to cool the cab quickly. The dual-level AC system, with a  $-14^{\circ}\text{C}$  to  $2^{\circ}\text{C}$  temperature differential, directs cooler air to the operator's upper body while sending warmer air toward the feet.

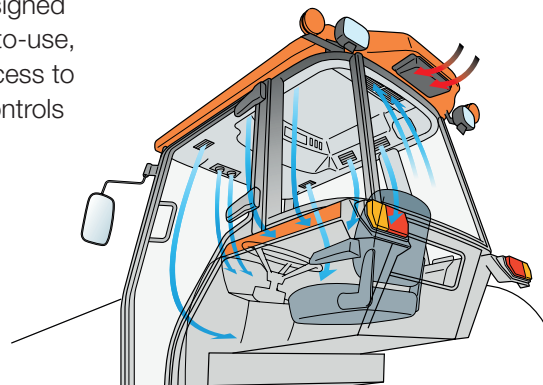

## Standard cab equipment

- AC/Heater with Internal/External Ventilation
- Pioneer Bluetooth and DAB radio
- 12 Volt Power Outlet
- 45/55/60 Amp Alternator
- Front Wiper and Washer
- Front Work Lights
- Interior Light
- Door-mounted Side Mirrors
- Wide Fenders
- Rear Window Defogger
- Rear Work Lights
- Air-Ride Seat

## Optional cab equipment

- Rear Windshield Wiper



## Deluxe Suspension seat

The suspension seat is specially designed to absorb shock to provide a comfortable ride even in harsh working conditions, and includes a handy swivel function. The optional Air-Ride seat adjusts its cushion to match your physique to provide optimal comfort even when negotiating rough terrain. It even includes a location for storage of your owner manual.



## Tilt Steering Wheel

The L2's tilt steering wheel delivers an extra-wide tilt angle for maximum comfort. Step on the adjustment pedal, tilt the steering wheel to your preferred position, and lock.



# and efficiency



### Ample Head Clearance

Increased head clearance for greater comfort and visibility.

### Electric PTO Switch

Our new switch makes PTO operation easier than ever. Conveniently located on the side console, one turn starts and one push stops the PTO.

### Simple Lever Layout

For easier access and smoother operation, the loader, hitch and optional remote levers are grouped on the right-side console.

### Extra legroom

The operator's seat has been positioned more to the rear for extra legroom. This not only enhances riding comfort, but makes getting in and out of the cab easier as well.

### Easy Power Supply Access

The power supply is located behind the seat for easier access.

## All the data you need

Stay up-to-date on the status of your L2 Series tractor at all times with the new IntelliPanel™.

### The IntelliPanel™ includes:

- Tachometer
- Indicator Lights Status
- Temperature Gauge
- Fuel Gauge
- Display mode – A simple touch of the menu's down button lets you make changes to the Standard indicator's digital information screen.
- Select button
- Stational PTO switch
- Beacon switch
- Cruise Control – To keep your working speed constant, simply adjust the cruise control switch to your desired speed, and go.



### Standard Indicators

The IntelliPanel's standard indicators display the hour meter, trip meter, fuel consumption, PTO revolutions, HST information, particulate matter accumulation, and maintenance information on the large and easy-to-read screen. The information can be switched easily with button operation. Furthermore, warning indicators, scheduled service alerts and DPF regeneration are also indicated on the panel to keep you informed at all times.

# Versatility and easy maintenance

Every L2 Series model is designed to be versatile and easy to use across a range of everyday tasks.

## FRONT LOADERS LA514EC/LA714EC/LA854EC/LA1054EC

Designed to match the performance of the L2 Series, our front loaders ensure precise operation and improved productivity. The L2-compatible front loaders feature outstanding lift capacity and lift height and rapid operation. Plus, loader lift and bucket dump cycle speeds are amazingly fast. The sleek design does more than simply match the curves of the L2 Series bonnet, it also encloses the hydraulic tubes.



### Easy Operation

When the front loaders work hard, you don't have to. The easy motion of the single lever controls all front loader operations, even allowing simultaneous operation of the boom and bucket.



### Skid Steer Type Universal Quick Attach (Optional)

The front loader can be used with optional Skid Steer type attachments, such as buckets, pallet forks and bale spears. Simple to attach and detach, no tools are needed.

### Third Function Valve (Optional)

For an even wider choice of implements, the L2 Series is available with a third function valve.

### Unique Kubota Rod Indicator Link

Kubota's innovative rod indicator link precisely detects boom height so that the operator can easily confirm that the bucket attachment is horizontal at any height, whether raised or lowered.

# ance

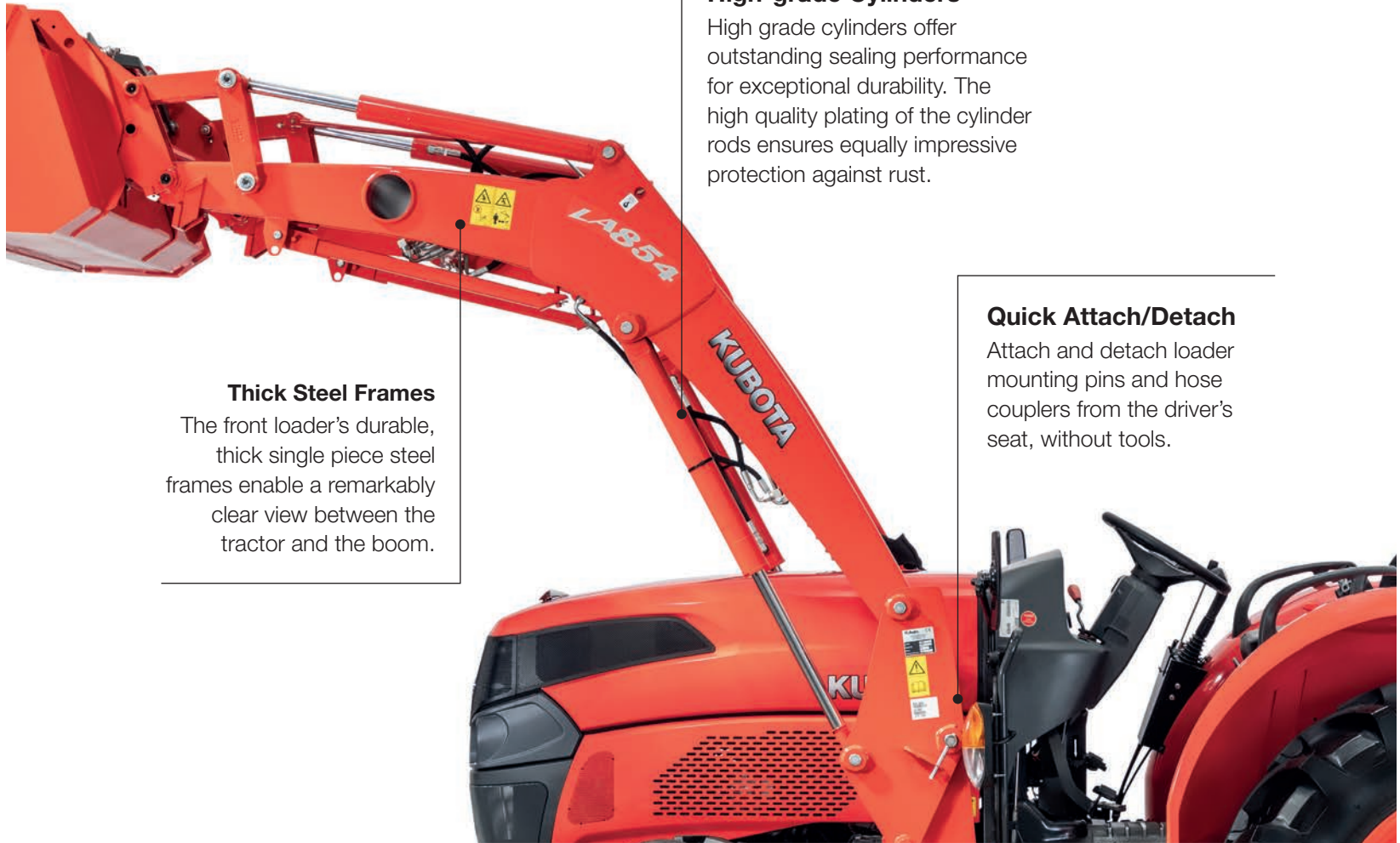

**Thick Steel Frames**  
The front loader's durable, thick single piece steel frames enable a remarkably clear view between the tractor and the boom.

**High-grade Cylinders**  
High grade cylinders offer outstanding sealing performance for exceptional durability. The high quality plating of the cylinder rods ensures equally impressive protection against rust.

**Quick Attach/Detach**  
Attach and detach loader mounting pins and hose couplers from the driver's seat, without tools.

## Simplified maintenance

Our open-floor seat system and full-open bonnet make simple maintenance easy. In addition, Kubota has added all-new independent headlights, as well as an audible alert that sounds when the fuel tank is full during filling.

### Full-open Bonnet

The all-metal, one-piece, full-open bonnet opens wide to make it simple to check the engine, the radiator screen and air and oil cartridge type filters. Its large exterior air intake area improves engine cooling performance, enabling the tractor to work better in high temperatures.



### Open-Floor Seat System

To make everyday maintenance as simple as possible, the L2 Series features a removable seat panel that is positioned over the transmission for easier access and service of hydraulic valves and sensor-related components.



# A specification to suit any task

Model	L2-351		L2-421		L2-501			L2-602	
Cab/ROPS	ROPS	ROPS	Cab	Cab	ROPS	Cab	Cab	Cab	
<b>Engine</b>									
Model name	D1803-M-E2-EU1	V2203-M-E2-EU2		V2203-M-E2-EU1	V2403-M-TE2-EU1	V2403-M-TE2-EU3	V2403-M-TE2-EU4	V2403-CR-TE4-EU2	
Displacement	l	1826(3)	2197 (4)		2434 (4)			2424 (4)	
Rated RPM	rpm	2700	2700		2600			2600	
SAE Output (gross)	KW/PS	27.3/37.1	33.5/45.5		36.5/49.6			45.8/62.3	
<b>Transmission</b>									
Type		FST	FST	HST	FST	GST	HST	HST	
F/R		16F/16R	16F/16R	3 range Dual Speed HST	16F/16R	24F/16R	3 range Dual Speed HST	3 range Dual Speed HST	
Creep gear		STD	STD	-	STD	-	-	-	
Max.Speed	km/h	29.4	29.8	29.7	29.1	29.3	29.6	29.6	
<b>PTO revolution</b>									
Rear	rpm	540/750	540/750	540	540/750	540	540	540	
Mid	rpm	N/A	N/A	Option	N/A	Option	Option	Option	
Steering	Hydraulic power steering								
3P control	Position control								
<b>Dimensions</b>									
Overall length (w/o 3P)	mm	3015	3170		3245			3245	
Overall width (min. tread)	mm	1430	1485	1555	1470	1560	1560	1560	
Overall height (w/ROPS)	mm	2415	2450	2250	2550	2365	2375	2375	
Wheel base	mm	1805	1895		1915			1915	
Min. ground clearance	mm	360	390	360	400	405	392	392	
Tread Front	mm	1150	1145		1340	1135	1135	1135	
Tread Rear	mm	1110-1385	1140-1310	1210 - 1410	1125-1325	1225-1325	1225-1325	1225-1325	
Turning radius (w/brake)	m	2.7	2.7		3.2			3.2	
Weight	kg	1545	1635	1775	1810	1805	1960	1995	2040
Fuel tank capacity	l	44	50		54			51	
Standard tyre size		7-16	8-16		9.5-16			9.5-16	
<b>Hydraulic</b>									
Hydraulic control system	Position control								
Pump capacity	l/m	31.5	37		35.6			35.6	
3-point hitch		SAE category 1	SAE category 1		SAE category 1			SAE category 1	
Max.lift force (at lift points)		1700	1750		1750			1750	

## Front loader specification

Model	LA514EC	LA714EC	LA854EC	LA1054EC	
Max. lift height (to bucket pivot pin)	mm	2449	2596	2863	2863
Clearance with bucket dumped	mm	1987	1990	2255	2255
Max. dump angle	deg.	41	45	45	45
Max. rollback angle	deg.	30	41	42	42
Lift capacity (pivot pin, max. height)	kg	613	860	1129	1129
Raising time	sec.	2.7	3	4.2	4.2
Lowering time	sec.	2.2	2.4	2.8	2.8
Bucket dumping time	sec.	2.5	3	3.3	3.3
Bucket rollback time	sec.	1.6	1.6	2.3	2.3



**KUBOTA (U.K.) LIMITED**  
 Dormer Road Thame, Oxfordshire, OX9 3UN.  
 Phone (01844) 268000



[www.kubota.co.uk](http://www.kubota.co.uk)

©2018 Kubota Corporation

Cat.No.4347-00-UK Printed in the UK. D.REX.'19-JANUARY.