

WHEEL LOADERS

W110 D | W130 D | W170 D



Agricultural focus. Industrial productivity.

New Holland W110 D, W130 D and W170 D wheel loaders are designed to meet the needs of large scale farmers, agricultural contractors, composting operators and biogas farmers where absolute loading performance is critical. Developed from machines proven in the toughest quarries, 24-hour recycling plants and countless intensive industrial applications, New Holland wheel loaders deliver tough, versatile and dependable performance.

The latest D Series wheel loaders now deliver more, with an all-new, best-in-class cab for improved visibility and unrivalled levels of comfort. New Holland wheel loaders have proven strength, performance and reliability. Now they offer exceptional levels of comfort to make them the operator's first choice.



Models	Engine Power (hp)	Bucket with bolt-on edge & QC (m ³)	Operating Weight Z-bar / LR (kg)	Tipping load straight Z-bar / LR (kg)
W110 D	144	1.7	11303 / 11431	7896 / 6781
W130 D	174	2.0	13305 / 13482	9497 / 8011
W170 D	197	2.4	15291 / 15494	10271 / 8708



Four engine working modes

All new cab with one piece curved windscreen

Up to eight LED work lights

New seat mounted armrest

High efficiency cube cooling package

NEF Tier 4B / Stage 4 power unit with HI-eSCR technology

Standard or Long Reach booms

Class leading visibility

45kph* road speed and boom suspension

Automatic centralised boom lubrication available

High flotation agricultural tyre choice

Heavy duty or standard duty axles

Torque convertor lock delivers performance and economy

Open differential manoeuvrability, locking differential traction

500hr engine service intervals

* On W170 D where local homologation allows

Ergonomic perfection.

Purpose designed for the D Series wheel loaders, the new generation cab offers class leading all-round visibility, comfort and operator security. Fully FOPS and ROPS certified, the new cab features a curved, one-piece windscreen offering a clear and uninterrupted view of the loader arm, with an excellent view to the front as the boom is raised. Visibility over the shoulder, to the sides and extremities is excellent, allowing the operator to place the machine accurately and with confidence in confined areas.

The seat mounted joystick control features a fully adjustable armrest, and the redesigned side console ensures all key functions are always within easy reach. Stay properly connected thanks to the Bluetooth radio with ceiling mounted microphone and remote Aux and USB sockets in the side console. The advanced ventilation package ensures the cab remains comfortable regardless of outside temperatures, with excellent filtration allowing operation in dusty environments. To further aid comfort, the cab is mounted on purpose designed isolation blocks to reduce noise and vibration and results in noise levels as low as 68dB(A).





Keep it cool

- Optional 30 litre portable coolbox keeps your drinks and snacks cool all day



Excellent ventilation

- Thirteen adjustable vents keep you comfortable and the cab glass clear
- A grid defroster takes care of the rear window in cold conditions



Cab filtration

- The cab filter cartridge combines high levels of filtration with generous capacity to allow extended periods between renewal
- There is a choice between CAT2 HVAC or CAT3 Activated carbon filters to suit every application
- The filtration system is linked to an advanced heating and air-conditioned ventilation package



Nice touches

- Dual internal cab mirrors and front and rear sun blinds increase safety and help reduce blindspots
- Right side window can be locked fully open to allow easy communication with people on the ground



Three seat options

A choice of three seats are available:

- For general re-handling work in grain stores and yards, the basic high comfort mechanical seat is ideal
- For working over rougher terrain, and in more extreme climates, the premium heated seat with air suspension is offered
- Operators working over rough terrain and spending long hours in the cab can specify a deluxe seat with active air suspension, head rest and heating

Controls.

New seat mounted armrest

The D Series wheel loaders have a new armrest and joystick design that has been developed to considerably reduce operator fatigue. The angle of the operators arm to the body has been carefully considered to minimise strain on the joints and not to compromise blood flow. Full seating support ensures good posture is maintained. The result? Less fatigue and benefits for the operator's long term health.



- Fully adjustable seat mounted armrest and arm cushion
- Armrest can slide horizontally independently of the seat for maximum comfort
- Armrest cushion can move vertically





Anti-glare LCD digital dashboard

- Push button, 8inch, LCD colour display provides the operator with a digital dashboard on the A pillar
- Navigation buttons allow the selection of other menus to include machine information and service settings and reminders
- Set a variety of working parameters such as starting gear, flow rates and engine modes
- When reverse is selected, the display will automatically show the rear camera view
- The display is anti-glare and automatically switches between day and night modes



Spoiled for choice

- Opt to use the column mounted forward/reverse shuttle lever, or switch to the FNR buttons on the joystick
- New joystick features FNR, auxiliary service and transmission kickdown functions as standard
- A 2nd auxiliary function can be specified on the joystick
- Single lever controls can be specified instead of a joystick

Everything within easy reach

- New side console features a neat button cluster keeping everything within easy reach
- Grouped and colour coded, the buttons feature lights to indicate if the function is active
- Rubber lined storage trays, two cup holders, storage net, remote AUX jack & USB sockets and 12 Volt power sockets are standard

Proven durability in the harshest of conditions.

New Holland has engineered the D Series wheel loaders to suit re-handling of root crops, compost, farm yard manure, grain, woodchip and other bulk materials. D Series wheel loaders also have the traction to work in deep muck or work on a steep silage clamp. These machines are designed with maximum productivity in mind, and equipped with the performance to keep up with the highest output forage harvesters.

Transmission

- New Holland W170 D models drive through a 45kph* Ecoshift five-speed powershift transmission
- The torque convertor can lock above 2nd gear to ensure 100% of engine power is sent to the axles
- Incorporating a 'power-inch' function, the transmission delivers optimised pushing power whilst eliminating roll back
- Both the W110 D and W130 D are offered with a 40kph four-speed powershift transmission with automatic or manual gear selection
- On all three models, the forward reverse shuttle can be operated via a steering column mounted lever or by forward / reverse buttons on the joystick
- To speed load cycles, releasing the drive pedal will bring the loader to a stop without the need to use the brakes. Even on an incline, there will be no roll back
- If the brake is pressed, full engine power will be diverted to the hydraulics for full loading performance





Rear axle oscillation

- Rear axle oscillation is not compromised by the large 750/65 R26 agricultural tyre option, allowing stability to be maintained while traversing large lumps of material encountered during grass silage and maize clamping



Heavy duty axles

- As standard, W170 D wheel loaders are fitted with heavy duty axles with an automatic 100% locking front differential and a fully open differential in the rear axle
- The front differential can also be manually activated by a foot switch
- Both the W110 D and W130 D are equipped with standard axles front and rear featuring limited slip differentials



Transmission kickdown

- All models have a transmission 'kickdown' feature activated by a button on the joystick
- This feature provides quick access to a lower gear to optimise power when climbing or pushing

* Where local homologation allows

Raising the standard.

New Holland W110 D, W130 D and W170 D wheel loaders are fitted with the mighty Z-bar boom, constructed from 45mm thick plate steel. The choice between Standard and Long Reach booms enables the machine to be specified to meet different handling priorities.

- In demanding agricultural and compost applications, the standard boom is ideally suited to working with silage forks, grain pushers and heavy-duty buckets
- The Long Reach boom increases dump heights by between 400 and 500mm. This longer boom is the ideal choice for re-handling duties to include intensive grain store management, composting, vehicle loading and stockpiling work, but still with the exceptional strength of the standard boom



Centralised grease points

- Where possible, all grease points are grouped together
- The optional auto lubrication system ensures regular and metered lubrication to reduce whole life operating costs



Automatic boom functions

- Lift to a predetermined height
- Return to a pre-set dig level
- Raise the boom to a set height for travel / cycling between load and dump
- Auto Glide boom suspension can be specified



Model	Hydraulic pump capacity
W110 D (l/min)	134
W130 D (l/min)	171
W170 D (l/min)	206

Hydraulic flow on demand

- Closed centre load sensing hydraulics are standard, the W170 D benefitting from tandem pumps for increased capacity
- A key element of the New Holland design is efficiency, the pumps delivering the required hydraulic flow upon demand
- When the brake pedal is pressed, full engine power is made available to the hydraulics but the system will only demand extra power as required for the task, adjusting flow in accordance with demands, for fast boom raise/lower or attachment crowd/dump

Efficiency without compromise.

Powered by 4.5L and 6.7L NEF High Efficiency Selective Catalytic Reduction HI-eSCR engines, New Holland W110 D, W130 D and W170 D wheel loaders combine proven dependability and class leading economy. Compliant with Tier 4B emission regulations, the NEF power units have been co-developed with New Holland sister company FPT Industrial, the pioneer of common rail fuel injection and producer of SCR power units proven in agriculture, transport and industry for over 10 years. The latest ECOBlue and HI-eSCR technology employs a newly developed electronic control unit that manages both the engine and the HI-eSCR exhaust to precisely match engine load, emissions and after-treatment. Using a dedicated closed loop system to continuously monitor NOx levels in the exhaust, HI-eSCR precisely monitors the flow of AdBlue. This will achieve more than 95% NOx conversion with minimised AdBlue usage.

New Holland has engineered the D Series wheel loader with the engine mounted far behind the rear axle, optimising the weight balance, eliminating the need to add extra "dead" weight. This approach also allows unhindered ground level access to the engine service points as there are no stacked radiators to get in the way. Due to the clean running characteristics of the power unit, engine oil change intervals are set at 500 hours. Combined with class leading fuel economy, NEF power units are used across the range of New Holland tractors, combine harvesters and forage harvesters meaning unrivalled after-sales support.

ECOBBlue
HI-eSCR

FPT
POWERTRAIN TECHNOLOGIES



Selectable engine modes

Choose from four different engine modes to tailor engine output to your requirements for maximum efficiency and fuel savings

- **ECO** - for maximum fuel efficiency
- **STANDARD** - for normal loading and carrying
- **MAX** - for aggressive pushing and climbing
- **AUTO** - for engine output that responds on the fly

Clever cooling package

- A key design feature of D Series loaders is the positioning of the engine behind the rear axle, with a cooling 'cube' between the engine and transmission
- The programmable reversible fan option forces air through each of the five main radiators individually, ensuring each one benefits from a direct flow of cool air
- Hot air is not passed between each radiator, reducing the load on the cooling fan which in turn reduces power consumption

Productivity enhancing options.



Tyres

- New Holland offers a wide choice of factory fit tyres for work over paved surfaces or for use over soft ground or working on steep sided silage clamps
- Wheel fender widths are available to match the selected wheel and tyre package



Quick hitch

- Attachment versatility and timeliness is guaranteed thanks to the heavy duty hydraulic quick hitch which is compatible with a wide variety of attachments



Joystick steering JSS

- The JSS system employs a joystick on the left armrest to control the steering function of the wheel loader
- Operator fatigue is greatly reduced and machine productivity is increased in repetitive-cycle operations such as truck loading and compost recycling, which typically follow a repetitive V pattern



LED lighting

- Enhance safety and turn night into day with up to 10* high intensity LED work lights

* 10 LED option available September 2017.

Spend time saving money.

All key service items can be reached from ground level, the one-piece engine hood lifting and closing electronically for simplified access. The cube cooling pack is designed to be easy to clean. The cab filter can be removed, cleaned and replaced with no need to climb steps or fiddle with difficult fasteners. A further boost is the optional centralised greasing system. New Holland D Series wheel loaders are engineered for performance, longevity and reduced whole life operating costs.



- One piece engine hood features electric opening on W130 D and W170 D models



- Hood switch, kill switch and remote battery terminals are grouped at the rear



- Easy access to each of the individual radiators allows easy routine cleaning



- Ground level service access makes the job simpler, faster and safer



- For security, the 246 litre fuel tank and 37 litre AdBlue tank are accessed only by raising the engine hood

New Holland Services.



Finance tailored to your business

CNH Industrial Capital, the financial services company of New Holland, is well established and respected within the agricultural sector. Advice and finance packages tailored to your specific needs are available. With CNH Industrial Capital, you have the peace of mind that comes from dealing with a financing company that specialises in agriculture.



Trained to give you the best support

Your dedicated New Holland dealer technicians receive regular training updates. These are carried out both through on-line courses as well as intensive classroom sessions. This advanced approach ensures your dealer will always have the skills needed to look after the latest and most advanced New Holland products.



New Holland App

Product apps - NH Weather - PLM Calculator - PLM Academy

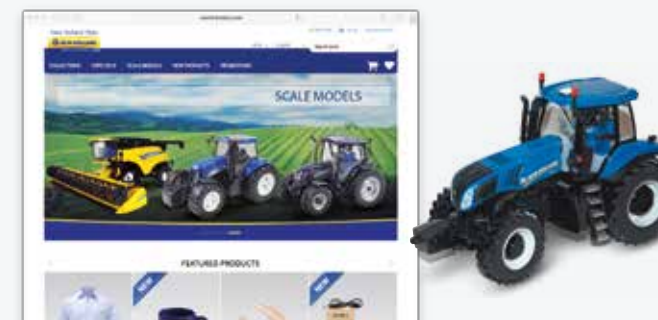

New Holland Style

Want to make New Holland a part of your everyday life? Browse the comprehensive selection on www.newhollandstyle.com. A whole range of items are available including hard wearing work clothing and a vast selection of scale models, together with so much more. New Holland. As individual as you.

Models	W110 D	W130 D	W170 D
Engine*	NEF N45	NEF N67	NEF N67
No. of Cylinders / Valves	4 / 4	6 / 4	6 / 4
Aspiration	Turbocharger with air-to air cooling		
Compliant with engine emissions regulations	Tier 4B / Stage 4	Tier 4B / Stage 4	Tier 4B / Stage 4
After treatment system	HI-eSCR	HI-eSCR	HI-eSCR
Fuel system - Common Rail multiple injection	●	●	●
Capacity (cm ³)	4500	6700	6700
Max. horsepower - ISO TR14396 - ECE R120 [kW/hp(CV)]	106/144@1800rpm	128/174@1800rpm	145/197@2000rpm
Max. torque - ISO TR14396 @1600rpm (Nm)	608	730	950
Diesel tank capacity (Litres)	189	248	246
AdBlue tank capacity (Litres)	37	37	37
Cooling system capacity (Litres)	22	26.8	28
Engine oil capacity (Litres)	12	13	13
Service interval (hours)	500	500	500
5-Speed powershift with Lock-Up clutch	-	-	○
Power Inch [Proportional declutching depending on braking intensity]	-	-	●
Number of gears (FxR)	-	-	5x3
Forward minimum speed (kph)	-	-	7
Forward maximum speed (kph)	-	-	45**
Reverse minimum speed (kph)	-	-	8
Reverse maximum speed (kph)	-	-	31
4-Speed powershift with Intelligent Clutch Cut Off (ICCO)	●	●	●
Number of gears (FxR)	4x3	4x3	4x3
Minimum speed (kph)	6	7	8
Maximum speed (kph)	40	40	45**
Reverse minimum speed (kph)	6.4	7	8
Reverse maximum speed (kph)	23	25	26
Electrical			
Alternator (Amps)	65	65	65
Battery	24V (2 x 12V)	24V (2 x 12V)	24V (2 x 12V)
Axles and differentials			
Rear axle total oscillation (°)	24	24	24
Standard axles with limited slip differentials	○	○	●
Heavy duty axles with open differentials and automatic	●	●	○
Hydraulics			
Valves	Rexroth Closed-center, Load sensing hydraulic. Main valve with 3 sections		
Steering	The steering orbitrol hydraulically is actuated with priority valve		
Automatic functions	Bucket Return-to-dig, Boom Return-to-travel, Boom height control		
Control type	Electro-hydraulic joystick control or two/three lever control		
Type of pump	Tandem Variable displacement pump		
Hydraulic oil tank capacity (Litres)	57	91	91
Main pump flow @ 2000rpm (Lpm)	134	171	206
Auxiliary circuit max. pump flow / pressure (Lpm / Bar)	162 / 227	162 / 227	260 / 224
Tyres			
Tyres	A wide selection of agricultural and industrial tyre sizes are available		
Brakes			
Service brake	Maintenance free, self-adjusting wet 4-wheel disc brakes		
Brake disc area (m ² /hub)	0.31	0.39	0.39
Parking brake	With negative brake all wheels are automatically stopped when the engine is stopped		
Disc brake area (cm ²)	58	58	82
Cab			
Protection against falling objects (FOPS) ISO EN3449	●	●	●
Protection against roll over (ROPS) ISO EN13510	●	●	●
Noise level in the cab - LpA - (ISO 6595/6396/3744) [dB(A)]	68	69	69
Noise level outside - LwA - (SAE J88 SEP80) [dB(A)]	101	101	101
Vibrations - (ISO 7096:2000) (m/s ²)	below 0.5	below 0.5	below 0.5

● Standard ○ Optional - Not available * Developed by FPT Industrial ** Where local homologation allows

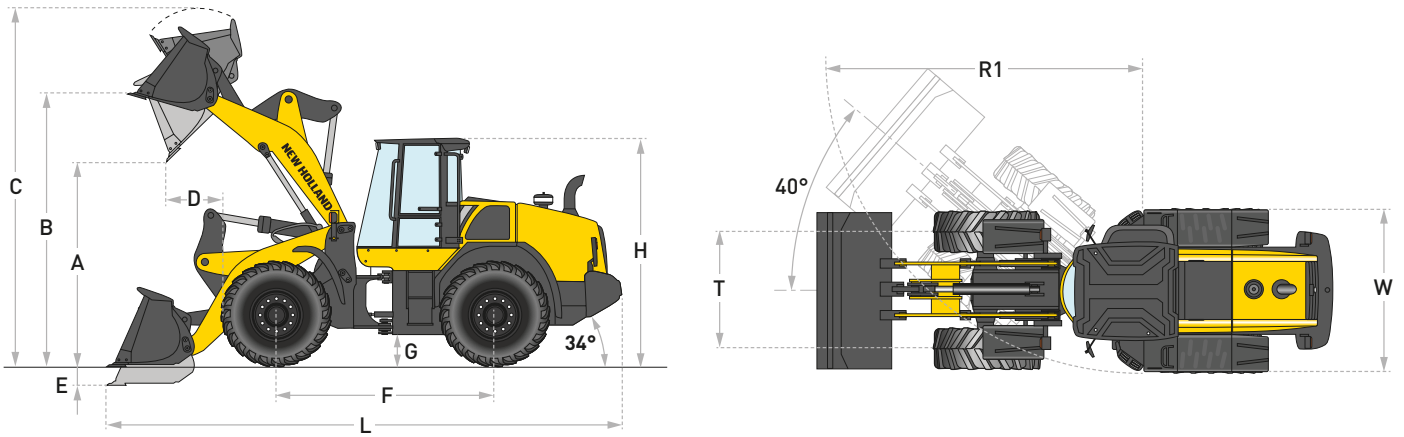

Loader speed

Raising time (loaded)	(sec)	5.4
Dump time (loaded)	(sec)	1.2
Lowering time (empty, power down)	(sec)	3.9
Lowering time (empty, float down)	(sec)	3.9

Dimensions

Z-bar bucket

Long Reach bucket

		1.9m ³		1.7m ³ w/QC		1.7m ³		1.7m ³ w/QC	
		edge	teeth	edge	teeth	edge	teeth	edge	teeth
Bucket capacity heaped	(m ³)	2.1	1.98	1.75	1.66	1.88	1.78	1.75	1.66
Operating load ISO 14397 - 1 Deflected Tires	(kg)	3526	3560	3371	3437	3058	3090	2882	2940
Bucket outside width	(mm)	2497	2540	2497	2540	2497	2540	2497	2540
Bucket weight	(kg)	857	794	1052	998	813	759	1052	998
Tipping load - straight	(kg)	8229	8297	7896	8039	7153	7219	6781	6905
Tipping load - Articulated at 40°	(kg)	7053	7121	6741	6874	6115	6181	5764	5880
Breakout force	(kg)	7599	8342	7019	7664	8130	8967	7016	7661
Lift capacity from ground	(kg)	8874	9005	7898	8440	8925	8984	8521	8673
A - Dump height at 45° at full height	(m)	2.62	2.55	2.48	2.41	3.04	2.97	2.92	2.86
B - Hinge pin height	(mm)	3605	3606	3605	3605	3985	3985	3984	3985
C - Overall operating height	(m)	4.74	4.74	4.74	4.74	5.06	5.06	5.12	5.12
D - Bucket reach at 45° dump	(m)	1.11	1.19	1.07	1.14	1.04	1.12	1.13	1.20
E - Dig depth	(mm)	83	85	102	105	110	108	137	140
F - Wheelbase	(m)	2.75	2.75	2.75	2.75	2.75	2.75	2.75	2.75
G - Ground clearance	(mm)	341	341	341	341	341	341	341	341
H - Minimum height (top of cab)	(mm)	3275	3275	3275	3275	3275	3275	3275	3275
L - Overall length with bucket on the ground	(mm)	6838	6937	6930	7030	7111	7207	7272	7371
R1 - Turning radius (Outside of Tires)	(mm)	5017	5017	5017	5017	5017	5017	5017	5017
T - Track setting	(m)	2.00	2.00	2.00	2.00	2.00	2.00	2.00	2.00
W - Overall width (on 20.5R25 L3 radial tyres)	(mm)	2478	2478	2478	2478	2478	2478	2478	2478
Bucket rollback in carry position	(°)	44	44	50	50	46	46	51	51
Max. rollback angle at full height	(°)	54	54	59	59	55	55	60	60
Machine operating weight with XHA2 (L3) tyres	(kg)	11098	11045	11303	11250	11192	11138	11431	11377

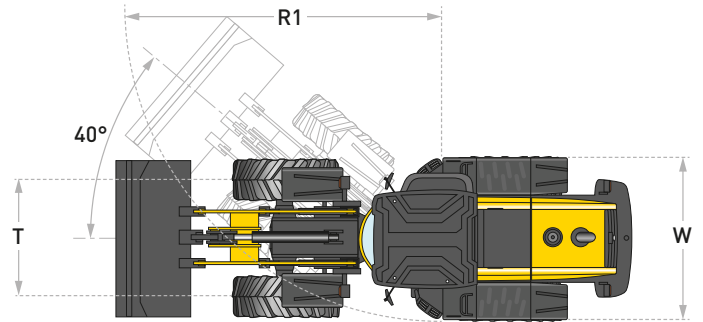
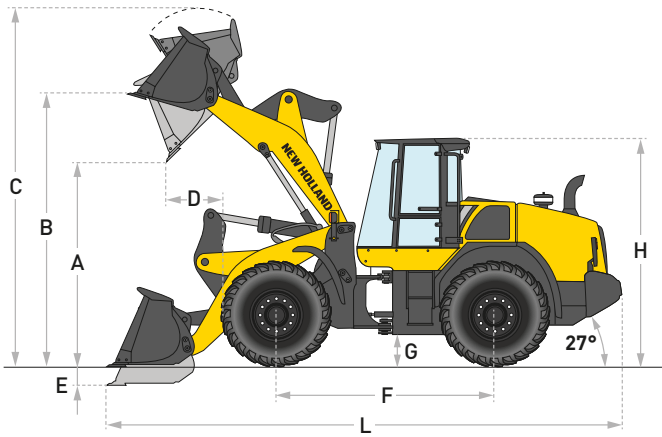

Loader speed

Raising time (loaded)	(sec)	6.3
Dump time (loaded)	(sec)	1.2
Lowering time (empty, power down)	(sec)	4.4
Lowering time (empty, float down)	(sec)	4.4

Dimensions

Z-bar bucket

Long Reach bucket

		2.3m ³		2.0m ³ w/QC		2.14m ³		2.0m ³ w/QC	
		edge	teeth	edge	teeth	edge	teeth	edge	teeth
Bucket capacity heaped	(m ³)	2.3	2.3	2.03	1.93	2.1	2.1	2.03	1.93
Operating load ISO 14397 - 1 Deflected Tires	(kg)	4241	4275	3983	4051	3641	3674	3344	3403
Bucket outside width	(mm)	2497	2540	2497	2540	2497	2540	2497	2540
Bucket weight	(kg)	924	871	1377	1328	878	825	1377	1323
Tipping load - straight	(kg)	10030	10099	9497	9649	8626	8692	8011	8139
Tipping load - Articulated at 40°	(kg)	8481	8551	7965	8103	7283	7349	6688	6805
Breakout force	(kg)	10099	10973	9448	10175	11548	12645	9475	10201
Lift capacity from ground	(kg)	9859	9992	8709	9243	11515	11577	10822	10949
A - Dump height at 45° at full height	(m)	2.75	2.68	2.71	2.63	3.26	3.21	3.22	3.15
B - Hinge pin height	(mm)	3833	3833	3832	3832	4258	4258	4256	4256
C - Overall operating height	(m)	5.04	5.04	5.05	5.05	5.46	5.46	5.47	5.47
D - Bucket reach at 45° dump	(m)	1.07	1.15	1.10	1.18	1.0	1.07	1.21	1.30
E - Dig depth	(mm)	86	87	87	90	85	86	92	95
F - Wheelbase	(m)	2.90	2.90	2.90	2.90	2.90	2.90	2.90	2.90
G - Ground clearance	(mm)	389	389	389	389	389	389	389	389
H - Minimum height (top of cab)	(mm)	3384	3384	3384	3384	3384	3384	3384	3384
L - Overall length with bucket on the ground	(mm)	7469	7567	7527	7633	7754	7852	7935	8041
R1 - Turning radius (Outside of Tires)	(mm)	5223	5223	5223	5223	5223	5223	5223	5223
T - Track setting	(m)	1.95	1.95	1.95	1.95	1.95	1.95	1.95	1.95
W - Overall width (on 20.5R25 L3 radial tyres)	(mm)	2478	2478	2478	2478	2478	2478	2478	2478
Bucket rollback in carry position	(°)	45	45	50	50	46	46	51	51
Max. rollback angle at full height	(°)	55	55	60	60	59	59	64	64
Machine operating weight with XHA2 (L3) tyres	(kg)	12853	12799	13305	13252	12983	12930	13482	13428

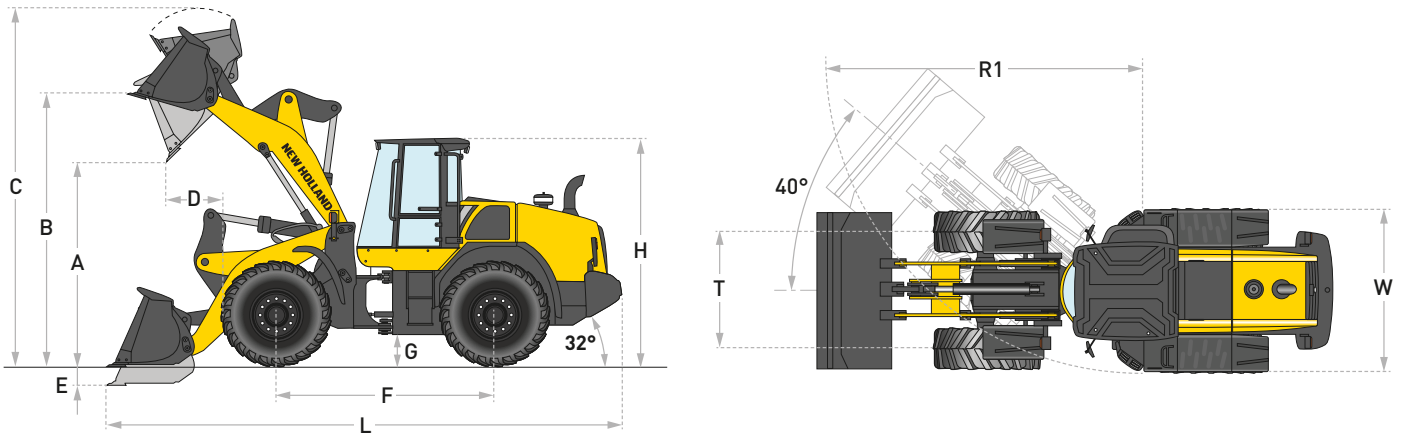

Loader speed

Raising time (loaded)	(sec)	5.2
Dump time (loaded)	(sec)	1.2
Lowering time (empty, power down)	(sec)	2.5
Lowering time (empty, float down)	(sec)	2.4

Dimensions

Z-bar bucket

Long Reach bucket

		2.7m ³		2.4m ³ w/QC		2.5m ³		2.4m ³ w/QC	
		edge	teeth	edge	teeth	edge	teeth	edge	teeth
Bucket capacity heaped	(m ³)	2.68	2.68	2.71	2.61	2.45	2.45	2.71	2.61
Operating load ISO 14397 - 1 Deflected Tires	(kg)	4764	4776	4129	4175	4065	4078	3484	3522
Bucket outside width	(mm)	2712	2726	2712	2726	2494	2510	2712	2726
Bucket weight	(kg)	1221	1202	1745	1726	1155	1134	1745	1726
Tipping load - straight	(kg)	11741	11766	10271	10382	10019	10046	8708	8797
Tipping load - Articulated at 40°	(kg)	9528	9552	8259	8350	8129	8156	6969	7044
Breakout force	(kg)	14599	15710	12116	12928	14593	15704	11991	12799
Lift capacity from ground	(kg)	13706	13735	12439	12558	11451	11487	10317	10406
A - Dump height at 45° at full height	(m)	2.93	2.83	2.73	2.63	3.32	3.32	3.13	3.02
B - Hinge pin height	(mm)	3976	3976	3974	3974	4371	4371	4369	4369
C - Overall operating height	(m)	5.33	5.33	5.35	5.35	5.72	5.72	5.74	5.74
D - Bucket reach at 45° dump	(m)	1.12	1.22	1.17	1.26	1.12	1.22	1.17	1.26
E - Dig depth	(mm)	77	91	67	80	79	93	69	83
F - Wheelbase	(m)	3.25	3.25	3.25	3.25	3.25	3.25	3.25	3.25
G - Ground clearance	(mm)	384	384	384	384	384	384	384	384
H - Minimum height (top of cab)	(mm)	3378	3378	3378	3378	3378	3378	3378	3378
L - Overall length with bucket on the ground	(mm)	7659	7807	7839	7987	8017	8164	8198	8344
R1 - Turning radius (Outside of Tires)	(mm)	5748	5748	5748	5748	5748	5748	5748	5748
T - Track setting	(m)	2.03	2.03	2.03	2.03	2.03	2.03	2.03	2.03
W - Overall width (on 20.5R25 L3 radial tyres)	(mm)	2558	2558	2558	2558	2558	2558	2558	2558
Bucket rollback in carry position	(°)	44	44	38	38	43	43	37	37
Max. rollback angle at full height	(°)	57	57	51	51	57	57	51	51
Machine operating weight with XHA2 (L3) tyres	(kg)	14767	14748	15291	15272	14904	14882	15494	15475

New Holland Top Service: customer support and customer information.



Top Availability

If you need information, or have an out of hours question, ring our toll-free number*. All day, every day, we are just a call away.



Top Speed

Express parts delivery: when you need it, where you need it!



Top Priority

Fast-track solution during the season: because your harvest can't wait!



Top Satisfaction

We drive and track the solution you need, keeping you informed: until you are 100% satisfied!



For more details, ask your New Holland dealer!

* Calls to the Top Service team are free from landlines in the United Kingdom and Republic of Ireland. UK-based mobile calls are also free, but Republic of Ireland mobile users should call 01 2421881 and this will be charged at your standard network rate.

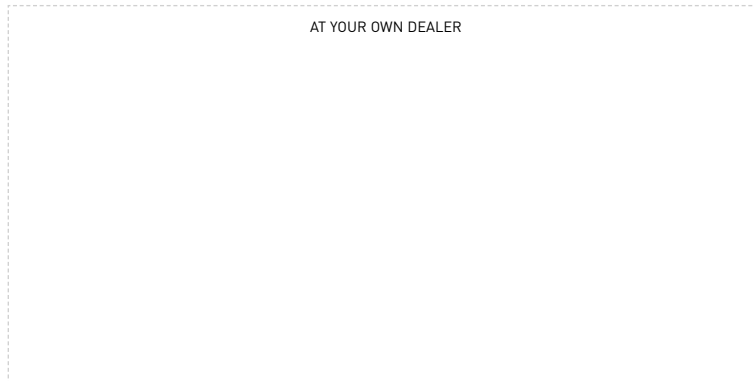

www.newholland.com/uk - www.newholland.com/ie

