

DEVELON

Crawler Excavators

DX160LC-7 HT



Maximum power	115 hp
Operating weight	16.8 t
Bucket capacity	0.5 - 0.75 m ³



DEVELON DX16oLC-7 HT CRAWLER EXCAVATOR:

MEET THE NEW GENERATION OF DEVELON MACHINES

Exceptionally powerful, yet environmentally-friendly, the DX16oLC-7 HT excavator features extraordinary fuel efficiency.



RAISE PROFITS, PRODUCTIVITY & FUEL EFFICIENCY

RELIABILITY

Reinforced castings and forged steel pivot points, and reinforced heavy-duty arm and boom to withstand high-impact materials. Mono boom or articulated boom for added versatility. Improved hydraulic line routing to protect your investment.

VERSATILITY

A new attachment mode, with a priority valve on the attachment, results in higher working efficiency when moving the arm and using the attachment at the same time.

YOUR SAFETY IS OUR PRIORITY

Rear and right side cameras as standard, anti-slip steps and platforms, as well as guard rails on upper structure. Optional: a 360° all-around view camera (AVM) can be linked with unique ultrasonic detection for maximum safety while working with people around. Large side mirrors, 10 powerful LED work lights (2 additional lights possible as an option), travel alarm.

PRODUCTIVITY

State-of-the-art bucket and arm digging forces. Delivers higher productivity and reduced fuel consumption in an efficient and comfortable work environment.

UNRIVALLED COMFORT

One of the most spacious cabs in the market, with low noise & vibration levels and excellent all-round visibility. Thanks to the heating – and even an optional cooling – functionality of the premium seat and improved air ventilation in the DX16oLC-7 HT, you can focus on the job at hand in any situation.





PROTECT YOUR INVESTMENT

High track undercarriage specifically designed for forestry application.

OPERATE AT EASE

The new Develon Smart Touch screen, an easy to read and use 8" touch screen, integrates all functions and settings of your machine in one place. Don't miss any important call thanks to the hands-free phone system. And forget fumbling with keyholes: unlock the door remotely, and start or stop the engine with the included Develon Smart Key.

ENGINE

Exceptionally powerful – with high torque at low revs – the new Develon engine combines reliability and low environmental impact. This Stage V compliant 4 cylinder engine delivers 86 kW at 2000 rpm.

FULL CONTROL OVER FUEL CONSUMPTION

The latest evolution of the legendary Stage V Develon D34 engine achieves greater fuel savings thanks to the 3rd generation of Smart Power Control (SPC3). Take full control over your fuel consumption with the settable engine shut-off.

ADVANCED FILTRATION

Highest efficiency filters & cleaners remove water, dust & particles to protect your investment optimally.

EASY MAINTENANCE

Maintenance data directly available from control panel. Easy access to all filters from ground level. Cooling compartment equipped with fine mesh for the intake air, to protect coolers and minimize downtime.



TOP PERFORMANCE AND FUEL EFFICIENCY

THE POWER TO RAISE PRODUCTIVITY

- The DX160LC-7 HT is equipped with the latest generation Develon engine
- Stage V compliant, this engine boasts extremely low emissions because reducing our environmental impact is paramount to us
- Exhaust gases are purified by Selective Catalytic Reduction (SCR) technology, a Diesel Oxidation Catalyst (DOC) and a Diesel Particulate Filter (DPF) with no maintenance before 8000 hours

EFFICIENT FUEL MANAGEMENT

- Choice of 4 power modes (Eco - Standard - Power - Power Plus) and automatic Smart Power Control system for optimal power and reduced fuel consumption in all conditions
- Engine auto-shut-off: shuts down the engine after the machine has been idling for a specified time. The operator can set the delay before shut-off via the Develon Smart Touch screen

VARIABLE PRESSURE TURBOCHARGER

Provides optimal air flow to the engine combustion chamber under all speed and load conditions, so that exhaust gas is cleaner and fuel economy is improved.

SPC3 (SMART POWER CONTROL)

2 systems (Variable Speed Control and Pump Torque Control) work together to improve efficiency while maintaining productivity. The system reduces the engine speed and adjusts the pump torque according to work conditions.

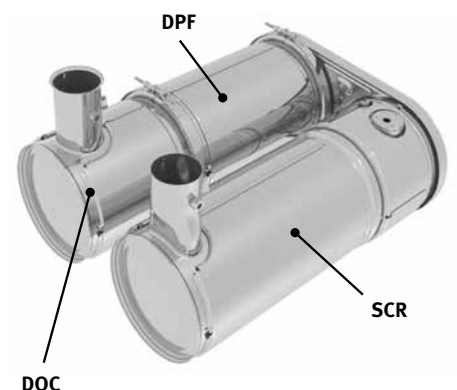



RELIABILITY – THE HABIT OF A LIFETIME

In your profession, you need equipment you can depend on. At Develon, we put durability and reliability at the core of our machines' development. Our materials and structures undergo stringent testing for strength and resilience under the most extreme conditions.

DESIGNED FOR LONG-TERM, ALL-ROUND, HEAVY-DUTY PERFORMANCE

REINFORCED TRACK FRAME

- The track frame reinforced with additional plate gives operators the confidence to travel in rough conditions
- Strong under cover to protect major components from any obstacles like wood trunks, rocks, etc.
- Reinforced track-frame to prevent any possible deformation while working in tough areas
- With additional protection on idler side

HIGHER GROUND CLEARANCE

The extra ground clearance allows the crawler excavator to move over tree-trunks and travel on un-paved roads

STRONG TRACTION SYSTEM WITH REINFORCED UPPER ROLLERS

- The reinforced upper rollers make our traveling system even more durable. The result: longer traveling time and distance, especially in harsher environments.
- In addition, the 18-ton class travel device on the DX160LC-7 HT provides more traction force for pulling heavy objects or piled logs.
- Higher position of upper roller for better structural strength and shoes grip as well as removal of debris.

CAR BODY CLEARANCE OF 615 MM

- Protect your investment, keep distance from obstacles
- 155 mm more versus standard track

BIGGER LOWER ROLLER DIAMETER: 150 MM

20% more versus conventional track.

TRACK SHOES

- The new DX160 High Track can be equipped with shoes from 800 to 900 mm.
- Perfect for forestry application, as well as recycling, agriculture, and areas with low ground pressure (with 900 mm shoes).

RELIABILITY

Reinforced castings and forged steel pivot points and reinforced heavy-duty arm and boom to withstand high-impact materials. Large, robust boom and arm cylinders for smooth, powerful operation. Advanced pin & bushing technology.

DURABLE UNDERCARRIAGE

Forged steel and deep-hardened top rollers; oil-lubricated rollers; heat-treated sprockets; deep-hardened, heat-treated, grease lubricated & longer life track chains.



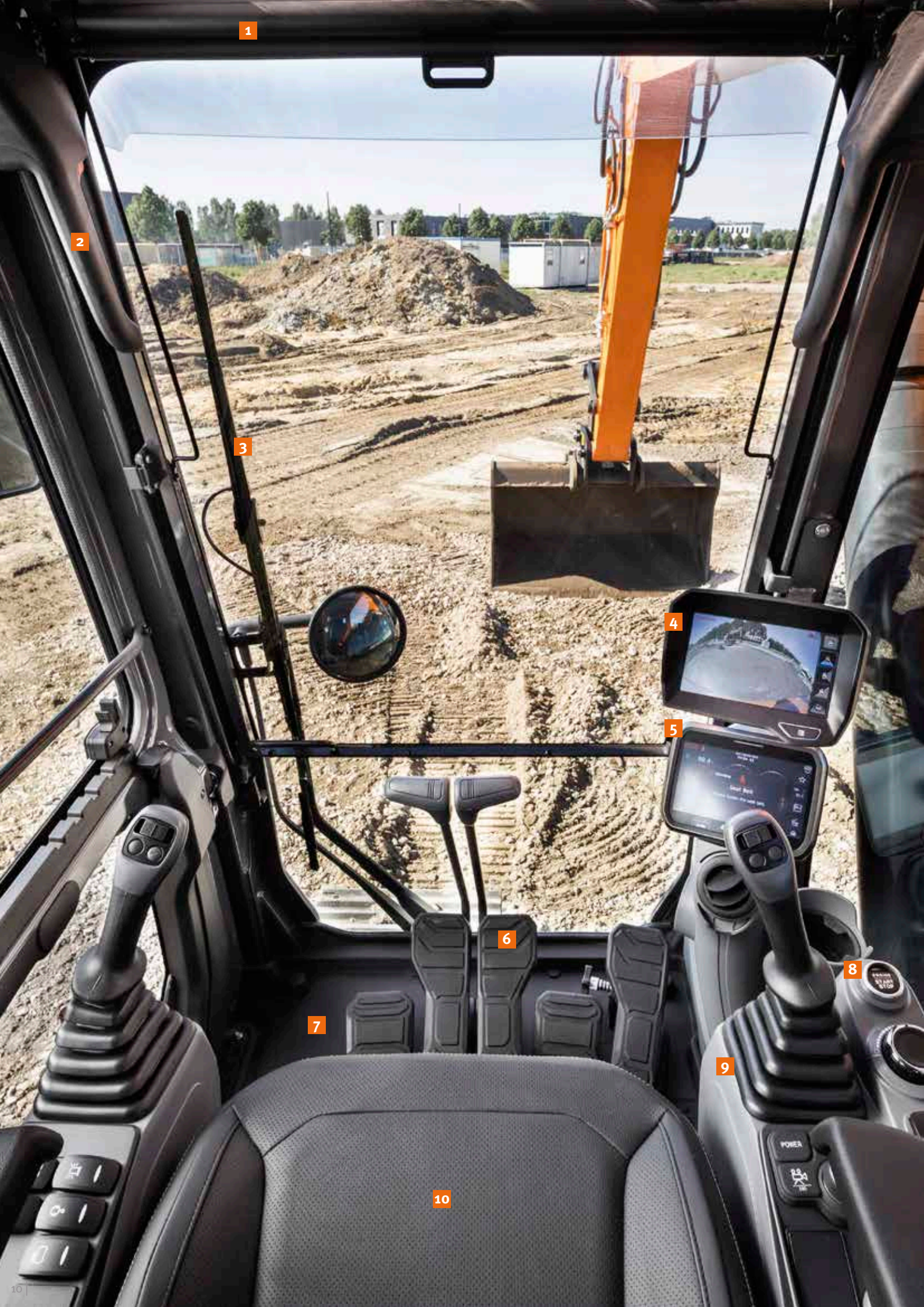

1

2

3

4

5

6

7

8

9

10

1. Sun visor
2. Window grip
3. Parallel wiper
4. 360° all-around view camera (AVM) (optional)
5. Develon Smart Touch
6. Redesigned pedals
7. Flat, spacious, easy-to-clean floor
8. Keyless start (Develon Smart Key)
9. Joysticks and switches are integrated in adjustable control consoles
10. Heated and cooled (option) seat
11. Improved visibility on the bottom right
12. Storage compartment for sunglasses
13. Separate seat height adjustment lever and cushion tilting function

OPERATING IN HIGH COMFORT

BEST-IN-CLASS OPERATOR ENVIRONMENT

The DX160LC-7 HT is designed to provide you with the best possible working conditions. The sophisticated state-of-the-art ROPS cab is pressurized and ISO-certified for your safety. A high-quality heated seat (and even seat cooling available as an option) with air suspension provides maximum operator comfort.

UNRIVALLED COMFORT

Comfortably seated, you benefit from a clear all-round view of the work site and have easy access to several storage compartments. Pedals, joysticks and armrests have all been designed for operator comfort and efficiency. Noise and vibration levels are remarkably low, and the effectiveness of the air conditioning and automatic climate control has been increased significantly. These features allow you to continue working for hours on end without feeling tired.

Finally, thanks to the hands-free system, you won't miss any important call, and you'll stay available to your customers as you operate the machine.

CAB SUSPENSION

The cab's suspension system (CabSus mount) dampens vibrations and provides outstanding protection against impact. This system absorbs shocks and vibrations much more effectively than a conventional silentblock suspension system.

DEVELON SMART TOUCH

The wide 8" touchscreen provides easy scrolling through the different menus, including power settings and auxiliary hydraulics settings. It also allows you to connect a Bluetooth device or listen to your favorite radio station.

360° ALL-AROUND VIEW CAMERA (AVM) SYSTEM (OPTION)

The 360° all-around view camera (AVM) system gives you full view of the machine's surroundings.





TAKE A SEAT IN BUSINESS CLASS

The ergonomic controls, the easy-to-view color monitor, and Develon Smart Touch place the machine firmly in your hands.

TOTAL CONTROL IN ALL SIMPLICITY

DYNAMIC POWER MANAGEMENT

- Automatic travel speed range selection (slow/fast)
- Activating the power boost control system increases digging force by 10%
- A 1-touch deceleration button immediately reduces engine speed to low idle
- Auto-idling starts 4 seconds (adjustable) after all controls are returned to neutral – reducing fuel consumption and noise levels in the cab

INTELLIGENT FLOATING BOOM MODE (OPTIONAL)

The “intelligent floating boom” function allows the boom to move up and down freely according to the application:

- Hydraulic breaker setting: during boom down operation, the boom moves down freely under its own weight. The result is reduced shock and vibration and longer breaker service life
- Full float setting: during boom down selection, the boom is allowed to rise and fall as required while the bucket is drawn across the ground

NEW FINE SWING FUNCTION

Another new standard feature is the Fine Swing function. This function minimizes the shaking that a lifted object undergoes at the start or stop of the excavator's swing movement – increasing the safety of nearby workers and preventing damage caused by the object falling from the excavator. When Fine Swing activates, the overrun shuts off, allowing the DX16oLC-7 HT to smoothly reach maximum swing speed. This also removes the shock from the turn reversal at the moment of stopping – resulting in a smooth stop.

4 WORK MODES AND 4 POWER MODES

These modes deliver the needed power, according to your specific application, while minimizing fuel consumption:

- Work modes: 1-way mode, 2-way mode, Digging mode and Lifting mode
With the 2-way mode, we now have a priority valve on the attachment line to increase the machine's productivity when using an attachment and moving the arm at the same time. A new mode is also available: dedicated for tilt rotator use, to maximize precision and minimize back pressure.
- Power modes: Power Plus mode, Power mode, Standard mode, Economy mode

EXPERT FINGERTIP CONTROL

- The new multi-function 8" Develon Smart Touch screen displays all useful information in a visual and intuitive format.
- At a glance, you can check the machine's status and settings to achieve optimal efficiency.
- Develon's unique jog shuttle switch gives you easy and precise control over all machine functions.
- Highly sensitive and low-effort joysticks enable you to work safely, smoothly and confidently.
- The proportional thumb switches on the joysticks can be mounted horizontally or vertically, as the operator prefers, for optimal control of hydraulic attachments.







SIMPLE MAINTENANCE FOR MAXIMUM UPTIME

MAINTENANCE ACCESS MADE SIMPLE

- Large guard rails are installed along with anti-slip steps and plates, for safer, easier access to the whole upper structure.
- The air conditioning filter is placed on the side of the cab for easy access. The filter's cover can be locked and opened with a key.
- A battery cut-off switch makes it easy to disconnect the battery for long-term storage.
- The hour meter display can be easily checked from ground level.
- Shut-off valves have been fitted on the pre-filter piping line and fuel tank drain piping to make servicing easier and prevent pollution from leakage.
- Engine parts can be easily reached via the top and side panels.
- For extra accessibility and servicing convenience, all filters (engine oil filter, fuel pre-filters, fuel filters and pilot filter) are located in the pump compartment.
- An electric transfer pump for initial priming of fuel filters is featured as standard.
- Fine mesh on the side doors and on the cooler itself filters the intake air going to the cooler for better cooling performance and reduced maintenance.

ADBLUE® TANK

Connected to the ECU (electronic control unit), sensors in the tank detect low levels of AdBlue® or any other system malfunction. Also equipped with an AdBlue® level indicator during refilling, to avoid over filling.

CENTRALIZED GREASING POINTS

To make maintenance easier, the greasing points have been centralized. An automatic lubrication system is available as an option.



TECHNICAL SPECIFICATIONS

ENGINE

Designed to deliver superior performance and fuel efficiency, the Develon G2 D34 diesel engine fully meets the latest Stage V emission regulations. To optimize machine performance, the engine uses high-pressure fuel injectors, air-to-air inter-cooler and electronic engine controls. 4-Cycle Water-Cooled, Wastegate Turbocharged, Diesel Oxidation Catalyst (DOC) & Selective Catalytic Reduction (SCR) and Diesel Particulate Filter (DPF), without EGR.

Model

Develon G2 D34

No. of cylinders

4

Rated power at 2000 rpm

SAE J1995 86 kW (115 hp)
SAE J1349 81.6 kW (109 hp)

Max. torque at 1400 rpm

46.9 kgf·m

Idle (low - high)

950 [±10] - 2000 [±25] rpm

Displacement

3409 cm³

Bore × stroke

98 mm × 113 mm

Starter

24 V / 5 kW

Batteries - Alternator

2 × 12 V, 100 Ah – 24 V, 100 A

Air filter

Double element air cleaner

UNDERCARRIAGE

Extremely robust construction throughout - made of high-quality, durable materials, with all welded structures designed to limit stresses.

- Track rollers lubricated for life
- Idlers and sprockets fitted with floating seals
- Track shoes made of induction-hardened alloy with triple grouser
- Heat-treated connecting pins
- Hydraulic track adjuster with shock-absorbing tension mechanism

Upper rollers

2

Lower rollers

7

Number of links & shoes per side

44

Link pitch

190 mm

Tumbler distance (std)

3180 mm

HYDRAULIC SYSTEM

The e-EPOS (Electronic Power Optimising System) is the brain of the excavator – minimizing fuel consumption and optimizing the efficiency of the hydraulic system for all working conditions. To harmonize the operation of the engine and the hydraulics, the e-EPOS is connected to the engine's electronic control unit (ECU) via a data transfer link.

- 2 travel speeds offer either increased torque or high speed
- Cross-sensing pump system for fuel savings
- Auto-deceleration system
- 4 operating modes, 4 power modes
- Flow and pressure control of auxiliary hydraulic circuits from control panel
- Computer-aided pump flow control

Main pump

2 × variable displacement tandem axial piston pump
Maximum flow at 2000 rpm 2 × 114 l/min

Pilot pump

Gear pump
Maximum flow at 2000 rpm 30 l/min

Relief valve settings

Implement	330 kgf/cm ²
Travel	350 kgf/cm ²
Swing	275 kgf/cm ²
Pilot	40 kgf/cm ²

HYDRAULIC CYLINDERS

High-strength steel piston rods and cylinder bodies. Shock-absorbing mechanism fitted in all cylinders for shock-free operation and extended piston life.

Cylinders	Quantity	Bore × rod diameter × stroke (mm)
Mono boom	2	110 × 75 × 1085
Articulated boom	2	110 × 75 × 970
Cylinder for articulation	1	140 × 85 × 720
Arm for mono boom	1	115 × 80 × 1108
Arm for articulated boom	1	115 × 80 × 1068
Bucket	1	100 × 70 × 900

CAB

The air-conditioning and heating systems are integrated for optimal climate control. An automatically-controlled fan supplies the pressurized and filtered cab air, which is distributed throughout the cab from multiple vents.

The heated air suspension, adjustable operator's seat includes a seat belt. The operator can adjust the ergonomic seat and joystick console separately according to his preferences.

A-weighted emission sound pressure level at the operator's position, LpAd (ISO 6396:2008)

Declared: 69 dB(A)

A-weighted sound power level, LwAd (2000/14/EC)

Declared: 100 dB(A)

Measured: 99 dB(A)

SWING MECHANISM

The swing mechanism uses an axial piston motor, driving a 2-stage planetary reduction gear bathed in oil for maximum torque.

- Swing bearing: single-row, shear type ball bearing with induction hardened internal gear
- Internal gear and pinion immersed in lubricant

Maximum swing speed

10.13 rpm

Maximum swing torque

4888 kgf·m

FLUID CAPACITIES

Fuel tank	265 l
Cooling system (radiator)	27.1 l
AdBlue® (DEF) tank	25 l
Hydraulic oil tank	145 l
Engine oil	12.6 l
Swing drive	3 l
Travel device	2 × 2 l

DRIVE

Each track is driven by an independent, high-torque axial piston motor through a planetary reduction gearbox. 2 levers / foot pedals guarantee smooth travel with counter-rotation on demand. The track frame protects the travel motor, brake and planetary gears. The multi-disc track brakes are spring-applied and hydraulic released.

Travel speed (low - high)

2.9 - 4.7 km/h

Maximum traction

Low speed 29.7 t / High speed 12 t

Maximum gradeability

35° / 70%

WEIGHT

	Shoe width (mm)	Machine weight (t)	Ground pressure (kgf/cm²)
Triple grouser	800	16.8	0.31
	900	17.1	0.28

COMPONENT WEIGHTS

Item	Unit	Weight	Remarks
Upper structure without front	kg	7120	With counterweight
Lower structure assembly	kg	7470	
Counterweight	kg	2200	
Front assembly	kg	2434	
4.6 m mono boom	kg	767	Including bushing
4.98 m articulated boom (upper / lower)	kg	592 / 384	Including bushing
Arm (2.5 m / 3.0 m)	kg	414 / 465	Including bushing

TECHNICAL SPECIFICATIONS

BUCKETS

Bucket Type	Capacity (m ³) SAE	Width (mm)		Weight (kg)	4600 mm mono boom		4980 mm articulated boom
		With side cutters	W/O side cutters		2500 mm arm	3000 mm arm	2500 mm arm
GP	0.24	534	464	275	A	A	A
	0.39	820	736	341	A	A	A
	0.45	911	821	381	A	A	A
	0.51	991	907	393	A	A	B
	0.59	1081	997	413	B	C	C
	0.64	1167	1083	435	B	C	D
	0.76	1339	1255	484	C	D	D
DC Class	0.45	-	1500	357	A	A	A
	0.54	-	1800	403	A	B	B
H Class	0.31	642	600	372	A	A	A
	0.42	792	750	420	A	A	A
	0.52	942	900	478	A	B	C
	0.60	1042	1000	510	B	C	D
	0.67	1142	1100	542	C	D	D
	0.74	1242	1200	585	D	-	-

A: Suitable for materials with a density less than or equal to 2100 kg/m³

B: Suitable for materials with a density less than or equal to 1800 kg/m³

C: Suitable for materials with a density less than or equal to 1500 kg/m³

D: Suitable for materials with a density less than or equal to 1200 kg/m³

Based on ISO 10567 and SAE J296, arm length without quick-coupler. For reference only.

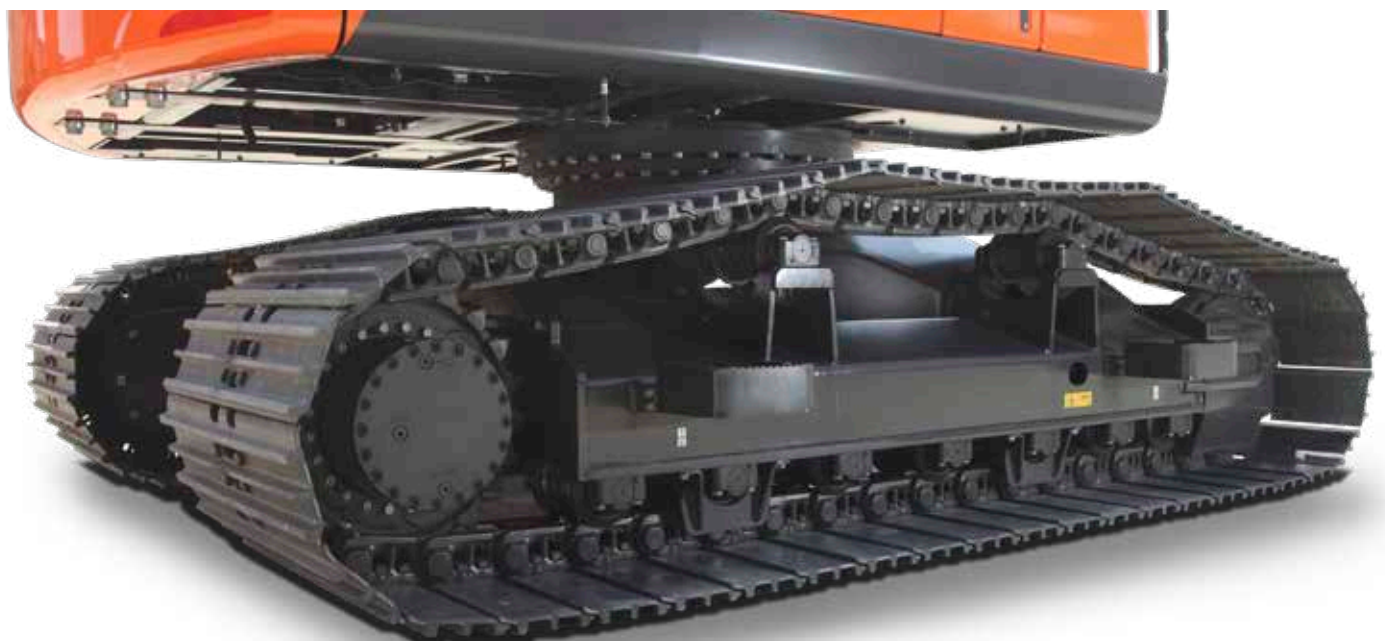

DIMENSIONS

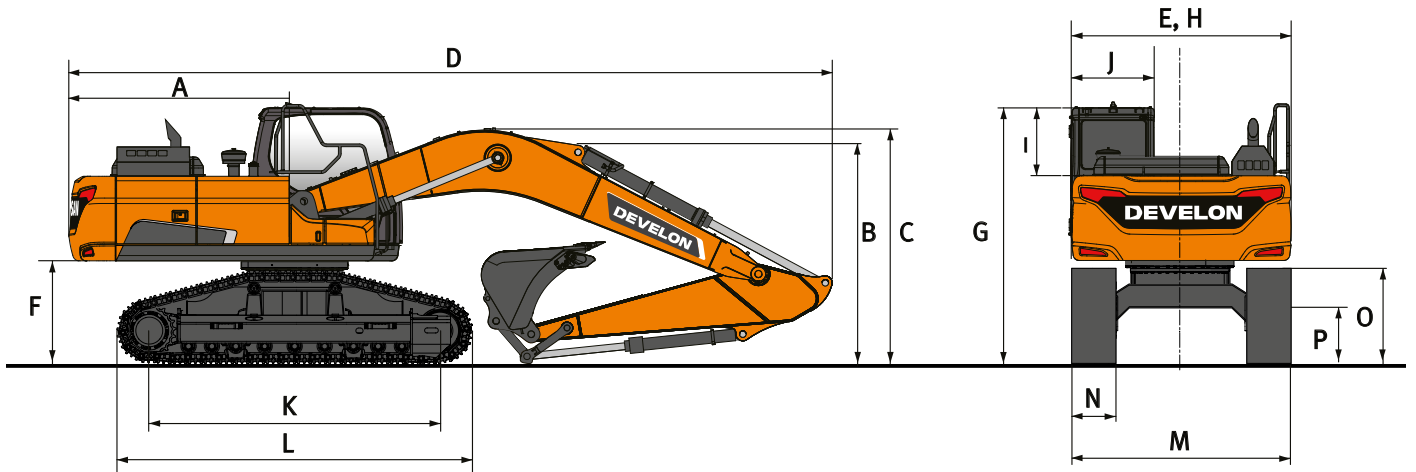

DIMENSIONS

	Unit	Mono boom		Articulated boom
Boom length	mm	4600		4980
Arm length	mm	2500	3000	2500
Bucket capacity	m³	0.51	0.45	0.45
A Tail swing radius	mm	2205	2205	2205
B Shipping height (boom)	mm	3020	2680	2950
C Shipping height (hose)	mm	3200	2830	3150
D Shipping length	mm	7720	7650	8015
E Shipping width	mm	3000	3000	3000
F Counterweight clearance*	mm	1175	1175	1175
G Height over cab	mm	3050	3050	2785
H House width	mm	3000	3000	3000
I Cab height above house	mm	830	830	830
J Cab width	mm	1010	1010	1010
K Tumbler distance	mm	3180	3180	3180
L Track length	mm	3925	3925	3925
M Undercarriage width	mm	3000	3000	3000
N Shoe width	mm	800	800	800
O Track height *	mm	946	946	946
P Ground clearance *	mm	615	615	615

*: without grouser

WORKING RANGE

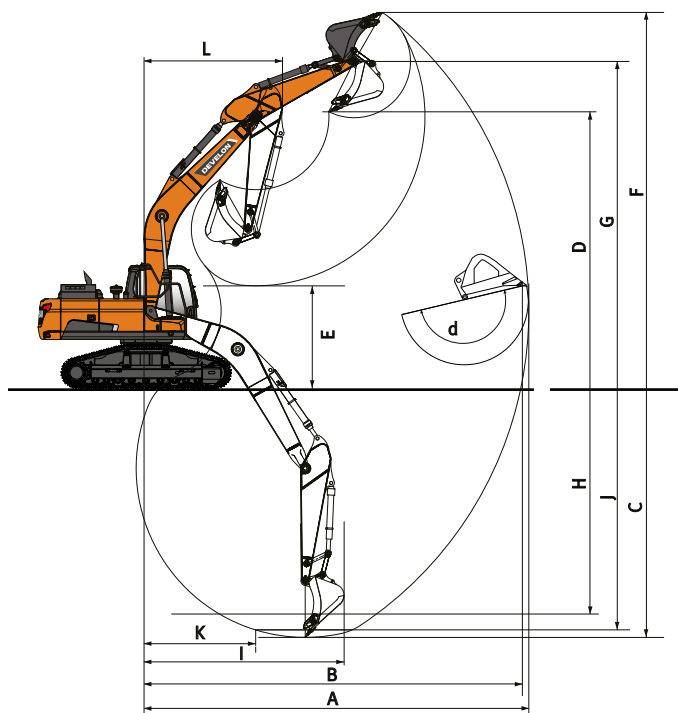

WORKING RANGE

	Unit	Mono boom		Articulated boom
Boom length	mm	4600		4980
Arm length	mm	2500	3000	2500
Bucket capacity	m³	0.51	0.45	0.45
A Max. digging reach	mm	8285	8665	8720
B Max. digging reach (ground)	mm	8080	8475	8530
C Max. digging depth	mm	5355	5850	5445
D Max. loading height	mm	6605	6720	7140
E Min. loading height	mm	2765	2005	2995
F Max. digging height	mm	8940	9025	9515
G Max. bucket pin height	mm	7815	7940	8355
H Max. vertical wall depth	mm	4210	4405	4400
I Max. radius vertical	mm	5605	5970	5725
J Max. digging depth (8'level)	mm	5115	5610	5335
K Min. radius 8'level	mm	1915	1825	910
L Min. swing radius	mm	2380	2625	2970
d Bucket angle	°	174	174	174











DIGGING FORCES (ISO)

	Unit	Mono boom		Articulated boom
Boom length	mm	4600		4980
Arm length	mm	2500	3000	2500
Bucket capacity	m³	0.51	0.45	0.45
BUCKET (Normal/Press. Up)	ton	10.5 / 11.1	10.5 / 11.1	10.5 / 11.1
ARM (Normal/Press. Up)	ton	6.2/6.5	5.6/6.0	6.2/6.5

LIFTING CAPACITIES

MONO BOOM • W/O BUCKET

(UNIT: 1000 KG)

A	1.5 m		3.0 m		4.5 m		6.0 m		Max. reach		A
											

Mono boom 4.6 m • Arm 2.5 m • Shoe 800 mm • Counterweight 2.2 t

7.5 m									2.57 *	2.57 *	4.06
6.0 m					3.63 *	3.63 *			2.12 *	2.12 *	5.65
4.5 m					4.08 *	4.08 *	3.46 *	3.31	2.00 *	2.00 *	6.52
3.0 m			7.32 *	7.32 *	5.17 *	4.95	4.42 *	3.23	2.01 *	2.01 *	6.96
1.5 m			7.32 *	7.32 *	6.40 *	4.71	4.48	3.13	2.15 *	2.15 *	7.06
0.0 m			7.55 *	7.55 *	6.8	4.55	4.40	3.06	2.44 *	2.44 *	6.82
-1.5 m	6.02 *	6.02 *	10.96 *	8.46	6.75	4.51	4.39	3.05	3.05 *	2.91	6.22
-3.0 m	10.10 *	10.10 *	9.42 *	8.61	6.30 *	4.59			4.68 *	3.86	5.12

Mono boom 4.6 m • Arm 2.5 m • Shoe 900 mm • Counterweight 2.2 t

7.5 m									2.57 *	2.57 *	4.06
6.0 m					3.63 *	3.63 *			2.12 *	2.12 *	5.65
4.5 m					4.08 *	4.08 *	3.46 *	3.36	2.00 *	2.00 *	6.52
3.0 m			7.32 *	7.32 *	5.17 *	5.02	4.42 *	3.28	2.01 *	2.01 *	6.96
1.5 m			7.32 *	7.32 *	6.40 *	4.78	4.55	3.18	2.15 *	2.15 *	7.06
0.0 m			7.55 *	7.55 *	6.91	4.62	4.47	3.10	2.44 *	2.44 *	6.82
-1.5 m	6.02 *	6.02 *	10.96 *	8.59	6.86	4.58	4.46	3.10	3.05 *	2.96	6.22
-3.0 m	10.10 *	10.10 *	9.42 *	8.74	6.30 *	4.66			4.68 *	3.92	5.12



Mono boom 4.6 m • Arm 3.0 m • Shoe 800 mm • Counterweight 2.2 t

7.5 m					2.66 *	2.66 *			2.31 *	2.31 *	4.70
6.0 m							2.29 *	2.29 *	2.01 *	2.01 *	6.13
4.5 m					3.50 *	3.50 *	3.34 *	3.34 *	1.94 *	1.94 *	6.93
3.0 m			6.06 *	6.06 *	4.62 *	4.62 *	4.06 *	3.25	1.97 *	1.97 *	7.35
1.5 m			9.44 *	8.82	5.96 *	4.74	4.49	3.13	2.12 *	2.12 *	7.44
0.0 m			8.43 *	8.43 *	6.80	4.55	4.38	3.04	2.42 *	2.35	7.22
-1.5 m	5.70 *	5.70 *	10.76 *	8.37	6.71	4.47	4.34	3.00	3.00 *	2.62	6.65
-3.0 m	8.88 *	8.88 *	10.11 *	8.47	6.74 *	4.5			4.44 *	3.31	5.64
-4.5 m			7.11 *	7.11 *					5.41 *	5.41 *	3.81

Mono boom 4.6 m • Arm 3.0 m • Shoe 900 mm • Counterweight 2.2 t

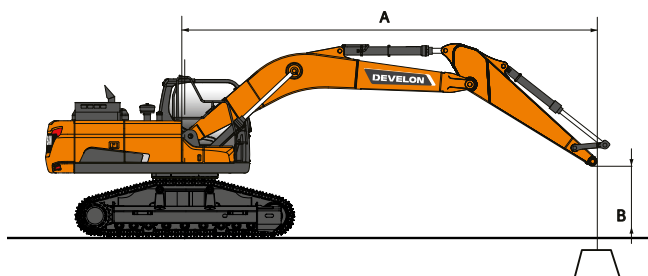
7.5 m					2.66 *	2.66 *			2.31 *	2.31 *	4.70
6.0 m							2.29 *	2.29 *	2.01 *	2.01 *	6.13
4.5 m					3.50 *	3.50 *	3.34 *	3.34 *	1.94 *	1.94 *	6.93
3.0 m			6.06 *	6.06 *	4.62 *	4.62 *	4.06 *	3.30	1.97 *	1.97 *	7.35
1.5 m			9.44 *	8.95	5.96 *	4.81	4.56	3.18	2.12 *	2.12 *	7.44
0.0 m			8.43 *	8.43 *	6.90	4.62	4.45	3.09	2.42 *	2.39	7.22
-1.5 m	5.70 *	5.70 *	10.76 *	8.50	6.81	4.54	4.41	3.05	3.00 *	2.66	6.65
-3.0 m	8.88 *	8.88 *	10.11 *	8.60	6.74 *	4.57			4.44 *	3.36	5.64
-4.5 m			7.11 *	7.11 *					5.41 *	5.41 *	3.81













 : Rating over front.
 : Rating over side or 360°.

- Lifting capacities are in compliance with ISO 10567:2007(E).
- The load point is at the end of the arm.
- * = The nominal loads are based on hydraulic capacity.
- The nominal loads shown do not exceed 75% of tipping loads or 87% of hydraulic lifting capacity.
- For lifting capacity with bucket, simply subtract the actual weight of the bucket from the values.
- The configurations indicated do not necessarily reflect the standard equipment of the machine.

LIFTING CAPACITIES

ARTICULATED BOOM • W/O BUCKET

(UNIT: 1000 KG)

A	3.0 m		4.5 m		6.0 m		7.5 m		Max. reach		A
											



Articulated boom 4.98 m • Arm 2.5 m • Shoe 800 mm • Counterweight 2.2 t

7.5 m			3.23 *	3.23 *					1.80 *	1.80 *	4.95
6.0 m			2.94 *	2.94 *	2.87 *	2.87 *			1.47 *	1.47 *	6.31
4.5 m			3.56 *	3.56 *	3.47 *	3.30			1.34 *	1.34 *	7.10
3.0 m			4.75 *	4.75 *	3.97 *	3.19	1.37 *	1.37 *	1.30 *	1.30 *	7.51
1.5 m			6.04 *	4.60	4.44	3.07	2.23 *	2.23 *	1.34 *	1.34 *	7.60
0.0 m			6.70	4.44	4.34	2.99			1.44 *	1.44 *	7.38
-1.5 m	8.19 *	8.19 *	6.66	4.41	4.32	2.97			1.67 *	1.67 *	6.83
-3.0 m	9.95 *	8.44	6.72 *	4.48					3.54 *	3.23	5.75

Articulated boom 4.98 m • Arm 2.5 m • Shoe 900 mm • Counterweight 2.2 t

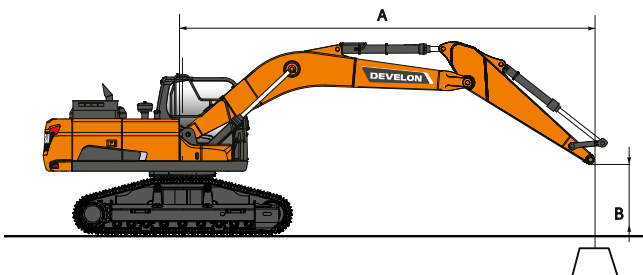
7.5 m			3.23 *	3.23 *					1.80 *	1.80 *	4.95
6.0 m			2.94 *	2.94 *	2.87 *	2.87 *			1.47 *	1.47 *	6.31
4.5 m			3.56 *	3.56 *	3.47 *	3.35			1.34 *	1.34 *	7.10
3.0 m			4.75 *	4.75 *	3.97 *	3.24	1.37 *	1.37 *	1.30 *	1.30 *	7.51
1.5 m			6.04 *	4.67	4.51	3.12	2.23 *	2.23 *	1.34 *	1.34 *	7.60
0.0 m			6.81	4.51	4.41	3.03			1.44 *	1.44 *	7.38
-1.5 m	8.19 *	8.19 *	6.77	4.48	4.39	3.01			1.67 *	1.67 *	6.83
-3.0 m	9.95 *	8.57	6.72 *	4.55					3.54 *	3.28	5.75



 : Rating over front.
 : Rating over side or 360°.

- Lifting capacities are in compliance with ISO 10567:2007(E).
- The load point is at the end of the arm.
- * = The nominal loads are based on hydraulic capacity.
- The nominal loads shown do not exceed 75% of tipping loads or 87% of hydraulic lifting capacity.
- For lifting capacity with bucket, simply subtract the actual weight of the bucket from the values.
- The configurations indicated do not necessarily reflect the standard equipment of the machine.

STANDARD AND OPTIONAL EQUIPMENT

● Standard ○ Optional

Engine

- Develon D34 G2 - Common rail 4 cylinder engine with direct fuel injection and electronic control, 4 valves per cylinder, vertical injectors, water cooled, turbo charged with air-to-air intercooler, Stage V compliant, SCR, DOC and DPF post treatment
- Auto-idle function
- Auto shut-off
- No EGR

Hydraulic system

- Boom and arm flow regeneration
- Fine swing mode, on or off from cab
- Swing anti-rebound valves
- Spare ports (valve)
- One-touch power boost function
- Double way line high flow + Breaker piping (PE3C)
- Smart Power Control (SPC3)
- Cylinder cushioning & contamination seals
- Double pump flow
- Clamshell piping (diverter valve from bucket cylinder)
- Hydraulic piping low flow for rotating or tilting tool (joystick control)
- Hydraulic piping for quick-coupler
- Floating boom

Cab & interior

- Pressurized sound-insulated and CabSus mounted cab
- Fully adjustable air suspension seat with heater
- Air conditioning with climate control
- Pull-up type front window sun roller blind and removable lower front window
- Sliding left window
- Intermittent upper and lower windshield parallel wiper
- Rain visor
- Rear window defroster switch
- Adjustable PPC wrist control levers for arm boom bucket and swing
- Joysticks & pedal provide proportional control of auxiliary hydraulic lines
- Pedal for auxiliary control 1 & 2 ways
- Jog shuttle switch
- Develon Smart Touch – 8" touch screen, all-in-one
- Attachment management system
- Engine speed (RPM) control dial
- Automatic travel speed
- 4 operating modes & 4 working modes
- Electric horn
- Cigarette lighter
- Ceiling light
- Cup holder
- Multiple storage compartments (e.g. document holder under seat)
- Heating and cooling lunch box
- Flat spacious easy-to-clean floor
- Keyless start (Develon Smart Key) & remote door lock/unlock
- Anti-theft protection
- 12 V spare power socket
- Serial communication port for laptop PC interface
- Remote radio ON/OFF switch
- Loudspeakers and connections for radio
- Radio + MP3 (stereo) with Bluetooth streaming and handsfree call system
- Rear and side view camera
- 360° all-around view camera (AVM)
- 360° all-around view camera (AVM) + ultra sonic detection
- Fully adjustable air suspension seat (heating & cooling)

Safety

- Roll Over Protective Structure (ROPS)
- Boom and arm cylinder safety valves
- Overload warning device
- Large guard rails on upper structure and steps
- Rotating beacon
- Punched metal anti-slip plates
- Hydraulic safety lock lever
- Safety glass
- Hammer for emergency escape
- Right and left rear-view mirrors
- Lockable fuel cap and covers
- Battery cut-off switch
- Engine restart prevention system
- Emergency engine stop switch and hydraulic pump control switch
- Guard rails (ISO 2867:2011)
- Parking brake
- LED pack 10x working lights (on the boom / body / and cab)
- LED 2x additional LED working lights added on top rear of the cab
- Falling Objects Guard System – top and front cab guards (ISO 10262 level II and SAE J1356)
- Front window upper and lower guards

Other

- 4600 mm mono boom – 2500 mm arm – 2200 kg counterweight
- DEVELON Fleet Management Web (telematic system)
- Auto shut-off fuel filler pump
- Double element air cleaner
- Fuel pre-filter with water separator sensor
- Dust screen for radiator/oil cooler
- Self-diagnostic function
- Alternator (24 V 100 A) – Battery (2 × 12 V 100 Ah)
- Hydrostatic drive with 2-speed power shift transmission
- Remote greasing for swing circle and work group pivot points
- 3000 mm arm for mono boom only
- 4980 mm articulated boom
- Develon buckets: full range of GP HD & rock buckets
- Develon breakers and Develon quick-couplers
- Automatic lubrication system
- Air compressor

Undercarriage

- Standard fixed undercarriage 3000 mm with 800 mm shoes
- 800 mm triple grouser shoes
- 900 mm triple grouser shoes



Powered by **Innovation**

**DISCOVER MORE:
DX160LC-7 HT**

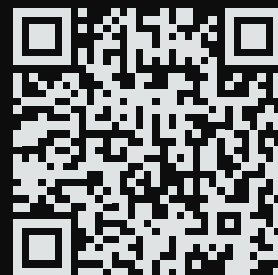

DEVELON

DOOSAN Infracore Europe s.r.o.
IBC - Pobřežní 620/3, 186 00 Praha 8-Karlín
Czech Republic

©2023 DEVELON D4601151-EN (04-23)

Certain specification(s) are based on engineering calculations and are not actual measurements. Specification(s) are provided for comparison purposes only and are subject to change without notice. Specification(s) for your individual Develon equipment will vary based on normal variations in design, manufacturing, operating conditions, and other factors. Pictures of Develon units may show other than standard equipment.