

CX5 & CX6

CX5.80 | CX5.90 | CX6.80 | CX6.90



A combine for every field.

The four-model New Holland CX5 and CX6 strawwalker combine series offers a specification choice to exactly match specific end user demands. Available with 600mm diameter, 4 drum threshing technology, these five and six-straw walker combines benefit from a host of developments to boost productivity in more demanding terrain.

The proven Triple-Clean™ and self-levelling Smart Sieve™ cleaning system – which operates on slopes of up to 25% – is now matched to the Opti-Speed™ variable speed strawwalker system. Proven in the higher capacity CX7 and CX8 combine models, Opti-Speed automatically adjusts the speed of the strawwalkers both up and down slopes to deliver productivity improvements of up to 10% in hilly areas. Other new features include standard hydraulic reel reversal, an automated clean out system to speed preparing the combine when moving between different crops and a new cab with even greater space, improved visibility and enhanced comfort.

Power comes from proven NEF or Cursor engines compliant with the Stage V emission standards. Fuel efficient and clean running, the power units develop maximum power outputs of 258hp - 340hp at a modest 2000rpm. In undulating terrain, these versatile combines have the power and specification to deliver level-land productivity and cleaning performance. For those that operate in more demanding terrain, CX5 and CX6 Laterale models offer slope correction of up to 18% on both sides. The CX5.90 Hillside model offers side hill correction of up to 38%.

All models are offered with a choice of headers to include High Capacity and Varifeed™ grain headers of up to 9.15m. For maize, five, six and eight row maize headers are available.

New Holland. Specification choice to match specific end user needs.



“Laterale” version maintains capacity on steep slopes

For sustained performance in hilly conditions, the CX5.90 and CX6.90 models are available in a “Laterale” versions. A simple and robust automatic levelling system provides a transversal slope correction of up to 18% on both sides. The Laterale system is in addition to the standard Triple-Clean™, self-levelling Smart Sieve™ and Opti-Speed™ straw walker speed control. The result? Optimized cleaning efficiency over difficult terrain

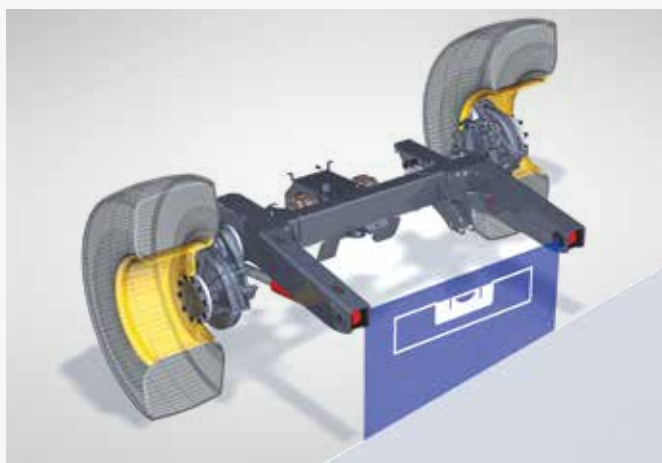

Hillside harvesting, the right way

For a professional combine operation in severe hillside conditions New Holland offers the CX5.90 Hillside. Efficiency of the separation and cleaning sections is ensured by two independent hydraulic systems: one for the lateral slope correction and one for the longitudinal corrections. Safety and field efficiency are increased as the traction wheels remain vertical. A powerful engine producing a maximum power of 313hp, the heavy-duty hydrostatic transmission and the large disc brakes ensure optimum performance in the field. Hillside combines are also available in a narrow version with a maximum overall width of 3.5m.



Laterale Models	Degree of correction (%) across the slope
CX5.90	18
CX6.90	18

Hillside Models	Degree of correction (%) across the slope		
	Uphill	Downhill	
CX5.90 Hillside Wide	38	30	10
CX5.90 Hillside Narrow	32	30	10

Models	Grain header cutting width (m)	Maize headers Number of rows	Max Power (hp)	Number of strawwalkers	Grain tank capacity (L)
CX5.80	4.57 - 7.62	5 / 6 / 8	258	5	8300
CX5.90	4.57 - 7.62	5 / 6 / 8	313	5	8300
CX6.80	4.57 - 9.15	6 / 8	313	6	9300
CX6.90	4.57 - 9.15	6 / 8	340	6	9300

CX5 and CX6.

Versatility comes as standard.

New Holland CX5 and CX6 match stylish looks with practical features to ease maintenance, enhance visibility and make cleaning and storage easier. The Harvest Suite™ Deluxe cab now features darker interior colouring to reduce glare and provides even greater levels of operator comfort too. Less visible are the detail changes to reduce downtime. There are now fewer grease points and the Auto-clean out function speeds swapping between different crops in the field, further enhancing the crop to crop flexibility. With New Holland, beauty is more than skin deep.

Excellent capacity

New CX5 & CX6 combines deliver outstanding field performance. The advanced threshing design and cleaning mechanism provides superior throughput allowing impressive forward speeds and daily output. Overall cleaning capacity has been greatly enhanced thanks to the innovative Triple-Clean™ cascaded system, which can provide a 15% increase in performance across the cleaning shoe.

Best-in-class versatility

Crop-to-crop flexibility has never been better thanks to easily replaceable concave sections. Furthermore, an easy to use choice of crop-specific settings fine tune your CX combine for optimum performance in any crop or crop condition. A wide choice of grain and corn headers ensure maximum combine versatility.

Great harvest quality

A clean sample of un-damaged grain kernels and straw quality in line with customer requirements are guaranteed by effortlessly fine tuning the combines many settings. With Opti-Speed™ strawwalker speed control, performance over undulating terrain is now even better.

Ease of operation

Practical automation of all basic combine functions adds to the operators peace of mind. The overall comfort of the Harvest Suite™ Deluxe cab enhances operator alertness while reducing the need for excessive concentration during the longest working days.

Standard 26.4cm wide IntelliView™ IV touchscreen monitor

EZ-Pilot™ PRO guidance system

Harvest Suite™ Deluxe cab

Four chain feeding system

Hydraulic reel reverse

Varifeed™ header





Up to 9300 litre grain tank

Four drum technology

Triple-Clean™ cascaded cleaning system

670L fuel tank

Up to 340hp engine with ECOBlue™ HI-eSCR 2 Stage V technology

Opti-Speed™ strawwalkers

Three-way residue management with Dual-Chop™ straw chopper

Smart Sieve™ system

Triple-Clean™ and Opti-Fan™ technology

Sectional concaves

Opti-Thresh™ system

A history of modern combining by New Holland.

- 1952:** Europe's first self-propelled conventional combine harvester rolled off the Zedelgem production line. The face of harvesting changed forever.
- 1955:** In the early days of self-propelled combining, farmers needed small units, and the M73 satisfied their requirements, with a threshing drum of just 73cm. The only ever combine with a sub one metre drum.
- 1958:** The M103 set new productivity records, with throughout of up to 7 tonnes per hour. Another impressive number: 27,510 M103s rolled off the production line in just under a decade.
- 1963:** M140 was the first 'modern' combine. Operator comfort and grain tank size were of prime importance. To increase productivity, it was the first model with a 1.25m diameter drum and boasted five strawwalkers.
- 1970:** Another harvesting revolution occurred: the advent of the rotary separator on the 1550 range. Forty years on, this technology is still used in flagship conventional combines today.
- 1977:** 8000 Series was the first to benefit from six strawwalker technology. Cab comfort, a reversible auger drive, Roto-Thresher™ for processing trailings and a double cascade cleaning shoe significantly upped the performance stakes.
- 1986:** The TX30 range was designed for professional harvesting operations. Outstanding visibility was coupled with improved harvesting autonomy and intuitive monitors for outstanding harvesting performance.
- 1994:** The TX60 developed up to 325hp and could be equipped with a mighty 9.15 metre header with lateral float technology.



Engineering excellence

The new midrange CX5 & CX6 models are manufactured in Plock, Poland in collaboration with New Holland's Centre of Global Harvesting Excellence in Zedelgem, Belgium. It was here in Zedelgem, over 100 years ago, that Leon Claeys built his very first threshing machine that revolutionised the way farmers harvested. Zedelgem is synonymous with harvesting firsts, in 1952 it produced the first European self-propelled combine harvester. Today, yellow blooded engineers are committed to developing the next generation of harvesting products. The sophisticated product development process and the extensive knowledge of a dedicated workforce of a World Class Manufacturing facility ensure the CX5 & CX6 range, together with all flagship harvesting products, the CR Twin Rotor™ combine, BigBaler large square balers and FR forage harvester, continues to set the benchmark in harvesting.

- 2003:** The CS range was aimed at mid sized farms who needed a machine that delivered productivity and reliability. Innovations such as Varifeed™ headers and Smart Sieve™ ensured high daily work rates were maintained. Fresh styling and a new modern ergonomic Discovery Cab heralded a new breed of midrange combine. Suspended on rubber isolation blocks, cab comfort and advanced controls set it apart from the competition.
- 2006:** The CSX Series combines built on the strong reputation gained by their predecessors, new Tier 3 engines with power increased to 333hp on the largest six strawwalker models, larger grain tanks, four-drum technology with Straw Flow™ beater and the introduction of the IntelliView™ II colour monitor.
- 2011:** The CX5000 & CX6000 models gained new modern styling in line with the rest of the combine family. Larger grain tanks, over the top unloading tube, ECOBlue™ SCR technology, Opti-Fan™ and greater crop to crop flexibility thanks to the sectional concaves. In addition, cab updates included the CommandGrip™ multifunction handle, and IntelliView™ III touchscreen.
- 2015:** CX5000 & CX6000 Elevation combines were introduced boasting 15% increased cleaning capacity thanks to the Triple-Clean™ cascaded system, improved residue management, larger rear tyres, larger grain tanks and larger IntelliView™ IV monitor.
- 2017:** New CX5 and CX6 Tier 4B combines featuring Opti-Speed™ variable speed strawwalkers to deliver up to 10% productivity increase, and all new Harvest Suite™ Deluxe cab for unrivalled operator comfort.

1994



2003



2006



2011



2015



2017



A perfect start.

High Capacity grain headers keep the CX going

A powerful crop flow from the very beginning: the large diameter reel, with easy reel adjustments, the aggressive knife action and the retractable fingers over the full intake auger width, ensure consistent crop feeding right from the start. No valuable time is wasted with the quick header coupling system and the trouble-free clearing of blockages.



Grain headers		CX5.80	CX5.90	CX6.80	CX6.90
Cutting width High-Capacity grain header*	(m)	4.57 - 7.32	4.57 - 7.32*	4.57 - 9.15	4.57 - 9.15
Cutting width Heavy-Duty Varifeed™ grain header*	(m)	4.88 - 7.62	4.88 - 7.62*	4.88 - 9.15	4.88 - 9.15
Cutting width High-Capacity Hillside grain header	(m)	–	4.57 - 6.10	–	–

* Not available on Hillside version – Not available

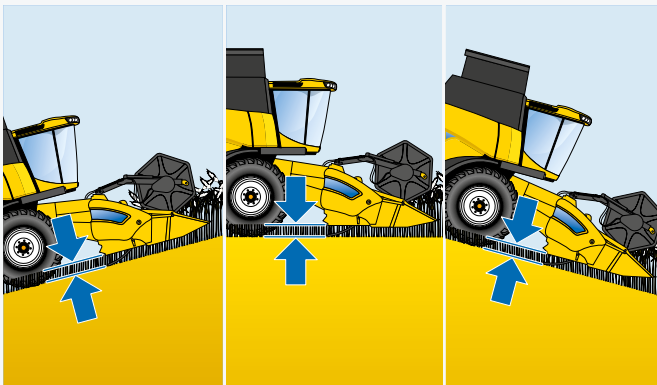

Autofloat™ II system

- Autofloat™ II system corrects the “exaggerated weight signal” for maximum header positioning accuracy in rolling field conditions
- Header bulldozing is avoided when working downhill and maintains correct stubble height when working uphill



Saving valuable seed

- The new hydraulic vertical knife prevents the aggressive pulling apart of the crop and reduces seed loss to a minimum
- When not required they can be stored conveniently on the header frame



Heavy-Duty Varifeed™ grain headers adapt to the crop

- The knife position on the Varifeed™ grain header is adjustable to work with the optimum header configuration in any particular crop
- The fore-aft adjustment reach of 575mm allows ideal knife positioning and ensures top cutting efficiency and correct feeding
- The electro-hydraulic adjustment is made from the cab and the header bottom is closed in all knife positions



Header trailers

Available for Varifeed™ headers from 7.62m – 8.5m, the new range of four wheel-steer New Holland header trailers offer security, stability and ultimate manoeuvrability at speeds up to 40kph. Self-aligning locating brackets and a secure and reliable locking-pin system ensure minimum downtime when detaching the header. An optional large lockable storage box and on board spare wheel complete the package.



Operator peace of mind

- Automatic Header Height Control allows a choice between stubble height control or header height compensation
- The lateral float system takes care of correct transversal header positioning in uneven fields
- For increased operator convenience, lateral float and Autofloat™ II systems operate automatically

A perfect match.

New Holland has developed a five, six and eight-row maize header line-up which has been engineered by design to perfectly match the CX5 & CX6 operating profile. Following extensive field testing, both the rigid and flipup versions deliver improved harvesting productivity and reliability.

Fit for operating in rolling fields

Operating New Holland maize headers in rolling or even hilly field conditions is no problem. When mounted on the "Laterale" models, there is a special drive-line to cope with the shifting header position.

Maize header		CX5.80	CX5.90	CX6.80	CX6.90
Flip-up maize headers	(number of rows)	6 - 8*	6** - 8*	6*** - 8	6*** - 8***
Rigid maize headers	(number of rows)	5 - 6 - 8*	5*** - 6 - 8*	6 - 8	6 - 8

* only in combination with specific tyre size and on flat field conditions ** Not available on Hillside version *** Not available on Laterale versions



Modern maize headers for modern maize farming

- Upgraded maize header offering satisfies modern demands and boost productivity and harvesting efficiency
- Shorter points better follow ground contours to prevent 'run-down' of valuable crops
- The gills direct any loose kernels to the back of the header minimizing waste
- Replaceable wear strips extend the headers lifespan and all points flip up on self-supporting gas struts for easy cleaning and maintenance



Row guidance boosts field performance

- Minimize operator stress and increase productivity with the Automatic Row Guidance system
- Digital sensors within the Auto Row Guidance system continuously monitor the combine's position and keep it on track for accurate harvesting
- Accurate row following reduces cob losses and increases profitability



Best-in-class chopping

- For fine chopping and superb spreading of the chopped material integrated stalk choppers can be fitted
- Row specific chopper heads ensure total coverage
- Renowned New Holland maize headers and their integrated stalk choppers are widely regarded as "the best-in-class"

Stalk Stomper tyre protection

- An optional Stalk Stomper kit is now available for fixed or flip-up maize headers
- Mounted on the header frame, the spring-loaded Stalk Stomper skids flatten the stubble in front of the wheels
- Uneven tyre wear and the likelihood of punctures is significantly reduced



Fully adapting to the maize crop

- Efficient threshing of maize and beans requires low drum rpm
- The optional drum speed reducer allows working with appropriate settings, adding to the combine's versatility



Enhanced crop flow for more efficient harvesting.

The CX5 and CX6 feed elevator features four chains with connecting slats for improved, continuous crop flow. From the Varifeed™ header through the elevator to the drum, a continuous crop flow is produced. This ensures bunching of crop in difficult conditions is greatly reduced, for more efficient throughput.





Non-stop stone protection

- The mechanical stone protection system simply knocks the stones into a dedicated trap before they reach the threshing drum
- This on-the-go system means zero slowdown during intensive harvesting days
- The trap can be emptied daily using an easy to reach lever



Unblocking in a matter of seconds

- Header blockages are instantly cleared by the hydraulic reversing system
- The entire header and elevator can be 'rocked' backwards and forwards to effectively unblock the machine for minimum downtime and maximum harvesting uptime
- New hydraulic reel reversal allows the operator to clear the header more easily of incoming crop if there is a blockage



Front face adjustment

Available on 6 strawwalker models, the new front face adjustment system allows the cutting angle to be adjusted mechanically to suit different headers or crops for optimized feeding.

Four drum combining with Opti-Speed™.

New Holland CX5 and CX6 combine models are offered with the four-drum Opti-Thresh™ that adds a Rotary Separator and Straw Flow™ beater. Opti-Thresh adapts to suit a wide variety of crops and conditions, boosting productivity without compromising kernel or straw quality. The design of the adjustable plates on the beater has been improved to further enhance raking of straw from the drum with reduced kernel damage.

To further enhance productivity and efficiency, all CX5 and CX6 models are fitted with the same Opti-Speed™ system employed on the larger CX7 and CX8 range. Opti-Speed™ automatically varies the speed of the strawwalkers to compensate for sloping ground. When climbing a slope, the walker speed is slowed to retain straw to ensure remaining kernels are shaken free from the crop residue. When travelling down a slope, the speed of the walkers is increased to help prevent straw falling forward and hindering crop flow.

Other developments include a revised beater design, featuring square profile adjustable beater plates to enhance straw rake-off from the drum, reduce kernel damage and perform better in damp conditions.

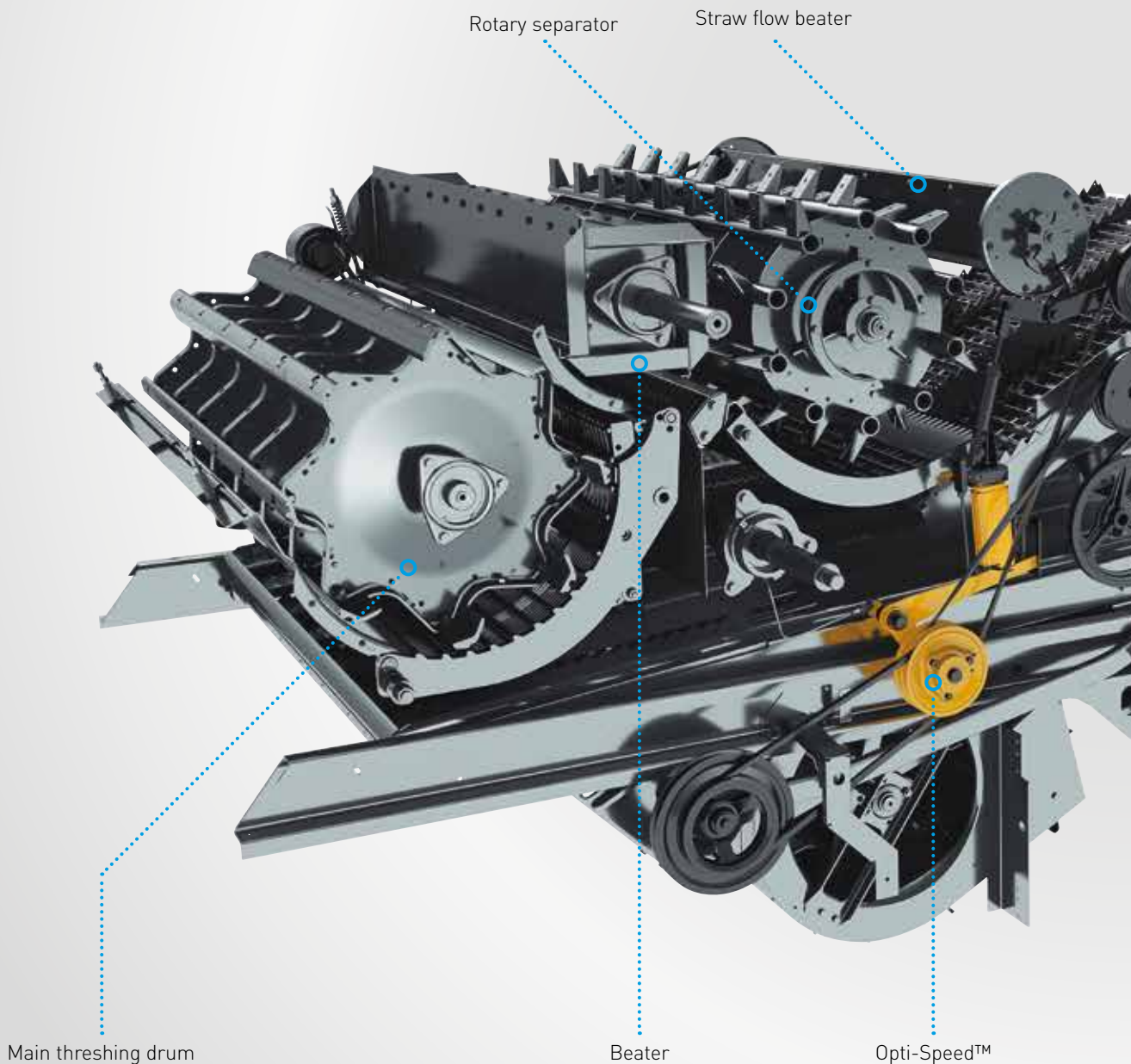

Opti-Speed™ variable speed strawwalkers: a New Holland exclusive

- Opti-Speed™ auto adaptive variable speed strawwalkers deliver up to a 10% productivity improvement
- Choose wheat, maize, rapeseed or rice setting, your CX5 and CX6 will automatically regulate strawwalker speed in relation to the crop selected
- When travelling uphill strawwalker speed reduces to keep every grain inside the machine
- On downward gradients, the speed is increased to prevent clogging and inefficient separation
- The system continually dialogues with the Opti-Fan™ and Opti-Clean™ systems to fine tune the strawwalker speed from 170-240rpm

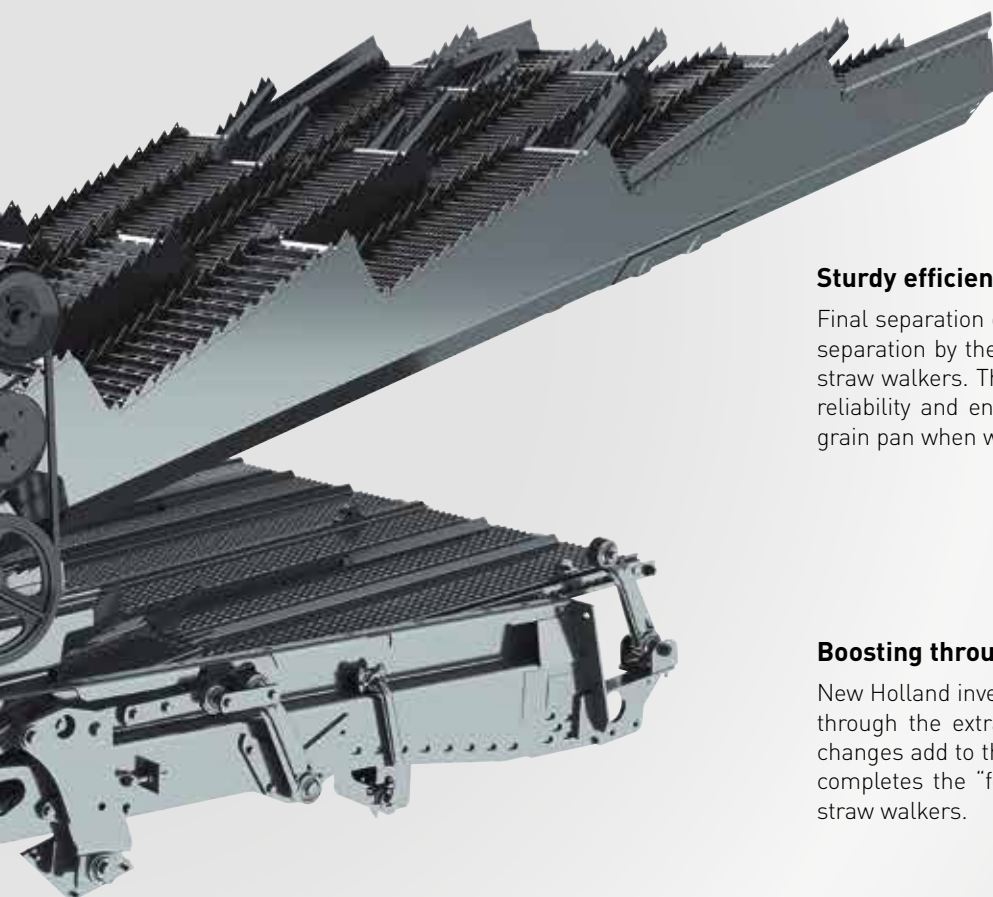

Sturdy efficiency

Final separation of any grain remaining after the intense forced separation by the four-drum technology is taken care of by the straw walkers. Their closed bottom adds strength and life-long reliability and ensures even delivery of separated grain to the grain pan when working on side slopes.

Boosting throughput the New Holland way

New Holland invented the Rotary Separator. Forcing more grain through the extra concave, additional rubbing and directional changes add to the separation efficiency. A Straw Flow™ beater completes the “forced separation” and directs the crop to the straw walkers.

Impressive threshing produces intact kernels

The rubbing action created by the 60cm diameter drum gently but firmly releases all grain kernels from the ears in even the thickest crop layer. With a wrap angle of up to 121 degrees the concave rubbing area is just huge. Drum speed adjustment and fine concave setting are cab-controlled.

Quick and easy adaptation to all crops.

Adding to their extreme versatility, New Holland CX5 & CX6 combine models have an broad range of adaptation possibilities that ensure outstanding performance in any number of crops and crop conditions. These avoid the need for compromise on grain or straw quality. The ease of adapting the machine from one crop to another is outstanding.

Four drum technology	CX5.80	CX5.90	CX6.80	CX6.90
Opti-Thresh™ system	●	●	●	●
Multi-Thresh™ system	●	●	●	●
Rotary Separator with Straw Flow™ beater	●	●	●	●
Full adjustability	●	●	●	●

● Standard

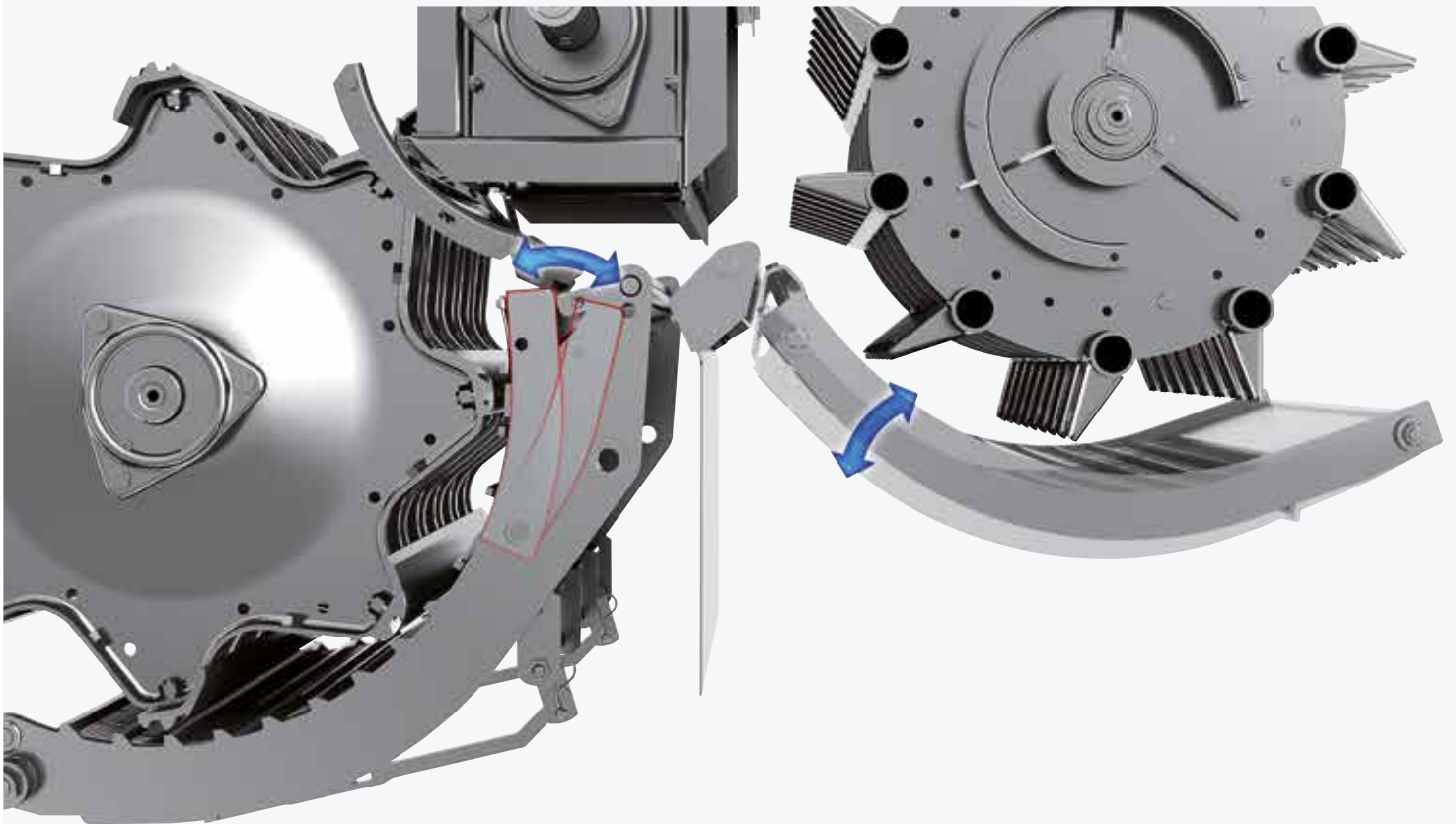

Rubbing on demand: the Opti-Thresh™ system

Adapting to grain maturity and yield can be done with the Opti-Thresh™ system by repositioning the rear part of the concave. When closed the concave reaches a full 121 degree angle of wrap. When the hinged top section is moved away from the drum, the rubbing action is less aggressive and the straw quality is improved. Changing the position of the Opti-Thresh™ concave section is now very easy, making it more convenient to use.

Flexible impact thanks to the Multi-Thresh™ system

Different cereal varieties or varying degrees of crop moisture can be matched thanks to the Multi-Thresh™ system with two adjustment positions of the Rotary Separator concave. This setting comes in addition to the double Rotary Separator speed range.



Standard sectional concave: easy to manage, quick to change

- Reducing the rebuilding time from 6 hours to 20 minutes! When switching from one crop to another, without removing the straw elevator, the lower concave sections can be replaced

Easy adjustments

- Opti-Thresh™ top concave section & the Multi-Thresh™ Rotary Separator concave adjustment handles are accessible on the right hand side of the machine
- Also the drive belt tensioner, for changing the Rotary Separator speed, is easily accessible

		<p>Standard drum, standard rasp bars & small grain sectional concave frame: suitable for small grains, maize and pulses</p>
		<p>Universal drum, standard rasp bars & small grain sectional concave frame: heavy duty high-inertia drum suitable for small grains, maize and pulses, and heavy straw conditions</p>
		<p>Universal drum, rice rasp bars & rice sectional concave frame: suitable for rice</p>
		<p>Universal drum, standard rasp bars & rice sectional concave frame: suitable for small grains and rice</p>

A steady flow of clean grain.



The cleaning efficiency of the New Holland CX5 & CX6 combine models matches their high threshing and separation capacity. Large adjustable sieves, moving in opposite directions, and a powerful fan delivering an even distribution of air, are complemented by ingenious extra features: the Triple-Clean™ cascaded cleaning system, the Smart Sieve™ concept that virtually eliminates side slope effects and the award-winning Opti-Fan™ system that adapts the air flow to the longitudinal slope of the combine.

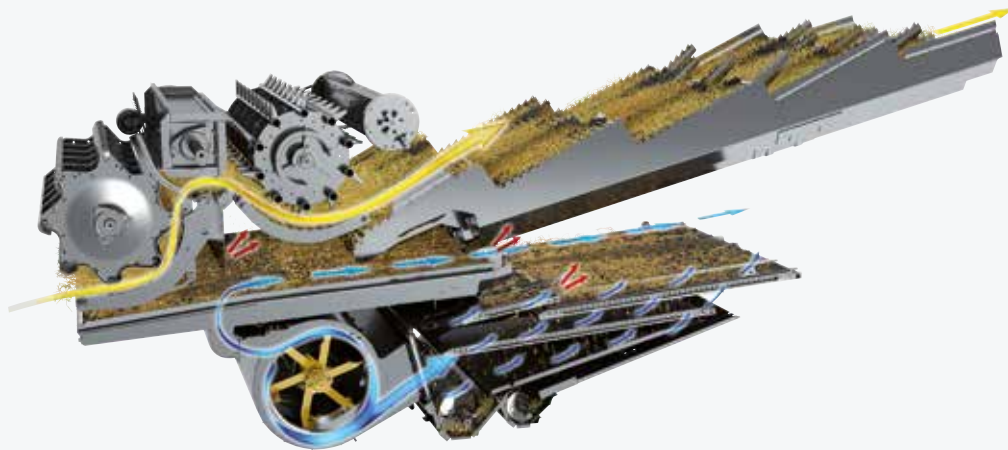

Triple-Clean™ cascaded cleaning system

The standard Triple-Clean™ cascaded cleaning system boosts cleaning capacity by as much as 15%. This simple yet innovative feature enhances cleaning by means of an extra cascade in the center of the grain pan, where an additional air blast removes large volumes of chaff and short straw ahead of the main sieves. This triple cascade approach ensures cleaning is not compromised when overall machine capacity is being optimized. Further capacity improvements include the new double flight cross auger which transfers grain to the elevator faster and can result in a 10% increase in throughput of the grain elevator system on 6 strawwalker models.



LED light

- Available as standard, the new LED light aids the operator when inspecting the cleaning shoe, day and night



Fingertip control

- For maximum cleaning efficiency in varying crop conditions, adjusting the sieves can be done from the cab



Easy grainpan removal

- Maintaining the aggressiveness of the grain pan steps in difficult crops like rape seed or maize may require regular cleaning. The CX combine's grain pan can be removed from the front

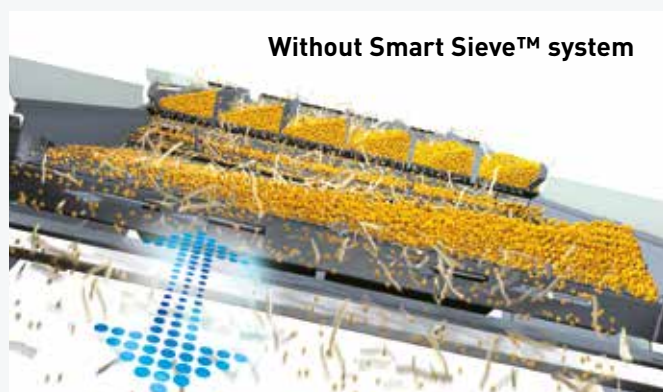

Without Smart Sieve™ system

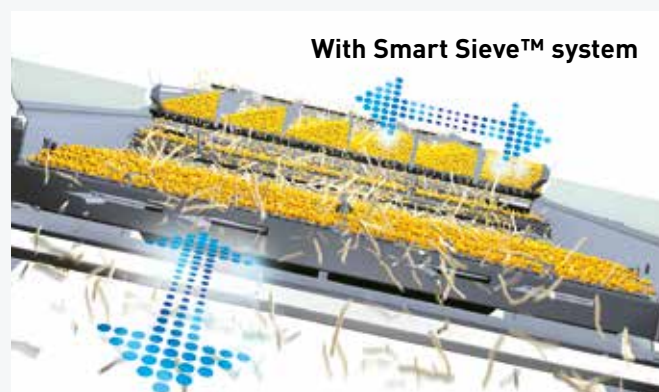

With Smart Sieve™ system

Smart Sieve™: neutralising the effect of side slopes up to 25% both sides

- On Laterale models, the standard Smart Sieve™ system creates a lateral sieve movement directing the grain kernels uphill
- An even layer of kernels and an even air-flow over the full width of the sieves maintains maximum cleaning efficiency

Really smart: no radial swing on flat fields

- The ingenious system that controls the lateral sieve movement is governed by the degree of the slope. To avoid unwanted radial swing / movement it incorporates a linkage to the sieve's pivot arm
- This patented concept neutralizes the radial swing and provides perfectly balanced sieve dynamics

Even smarter: automatic kernel size adaptation

- The lateral sieve movement is determined not only by the degree of the slope: the fan speed, which depends on the kernel size is also taken into account to determine the optimal throwing angle

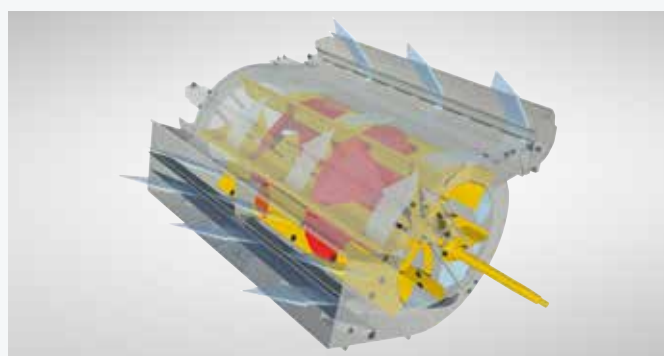

Redesigned fan

- Triple-Clean™ Opti-Fan™ efficiently blows air through three outlets
- Two outlets to aid cleaning on the sieves and one to direct air between the preparation tables
- A key design feature is the fan rotor deflector plate, which achieves a uniform distribution of air between the three outlets

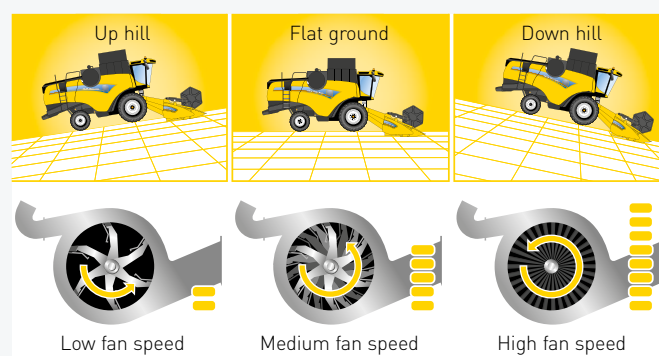

Dealing with longitudinal slopes: the Opti-Fan™ system blowing precision

- The award-winning Opti-Fan™ system consists of a simple yet very effective way of correcting fluctuations in the speed of grain flow across the cleaning shoe
- Whether working up-hill or downhill, the fan speed automatically adapts to the direction and to the degree of the slope

High volume grain management.

High unloading rates reduce time loss to a minimum. Unloading into even the highest type of grain trailer is easy, the over-top unloading system featuring a choice of 4.75m, 5.50m and new 6.4m unloading auger lengths. Excellent visibility of the unloading auger ensures smooth and uninterrupted harvesting when unloading on the move. High grain tank capacities deliver increased field autonomy.



High capacity, complete filling

The powerful bubble up auger ensures the entire capacity of the grain tank can be completely filled with no wasted space.

Basic models		CX5.80	CX5.90	CX6.80	CX6.90
Grain tank capacity / Hillside version	(l)	8300	8300 / 7300	9300	9300



A professional way to deal with chaff and straw.

High quality straw, ideal for baling is the result of the wide range of adjustment possibilities. In situations where the straw is chopped, the correct management of residue is important, especially where reduced tillage methods are practiced.

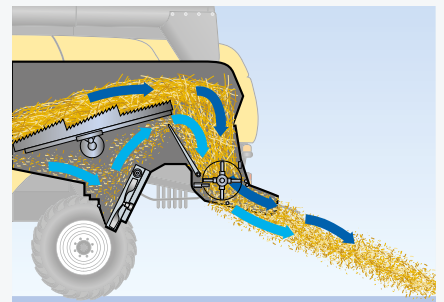
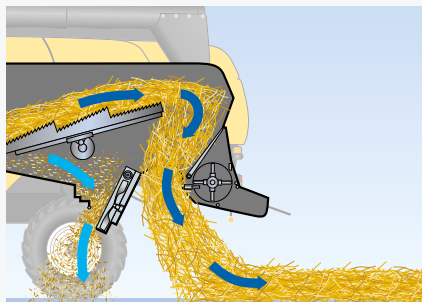

High quality bales with good bedding characteristics

- The unbroken straw found in the swath of a CX5 & CX6 combine is the result of the low threshing aggressiveness
- The new straw hood has adjustable rakes which allow control of the swath width

Three-way residue management: in the swath or on the stubble

- The twin-disc chaff spreader spreads the chaff onto the stubble before the straw hits the ground
- Straw feed value can be increased by directing the chaff into the straw to be baled
- A chaff blower can mix the chaff into the straw to be chopped for distribution together with the chopped straw
- The chaff spreader has adjustable deflector plates to fine tune the spread width to the header size and achieve uniform chaff distribution

No escape: uniform straw chopping

- The Dual-Chop™ straw chopper includes an extra rake preventing long straw from escaping
- Repeated cutting of these stems ensures very uniform chopping

Powerful. Respect. For you. For your farm. For the future.

The CX5 & CX6 combines benefit from the productivity enhancing features of FPT Industrial Nef and Cursor 9 engines, equipped with ECOBlue™ HI-eSCR 2 technology for Stage V compliance. The proven ECOBlue™ technology uses AdBlue to transform the harmful nitrogen oxides contained in the exhaust gas into harmless water and nitrogen. This after-treatment system is separate from the engine which means the engine only breathes clean, fresh air. This results in clean running power units that offer improved performance and enhanced fuel economy.



Sustainable Efficient Technology

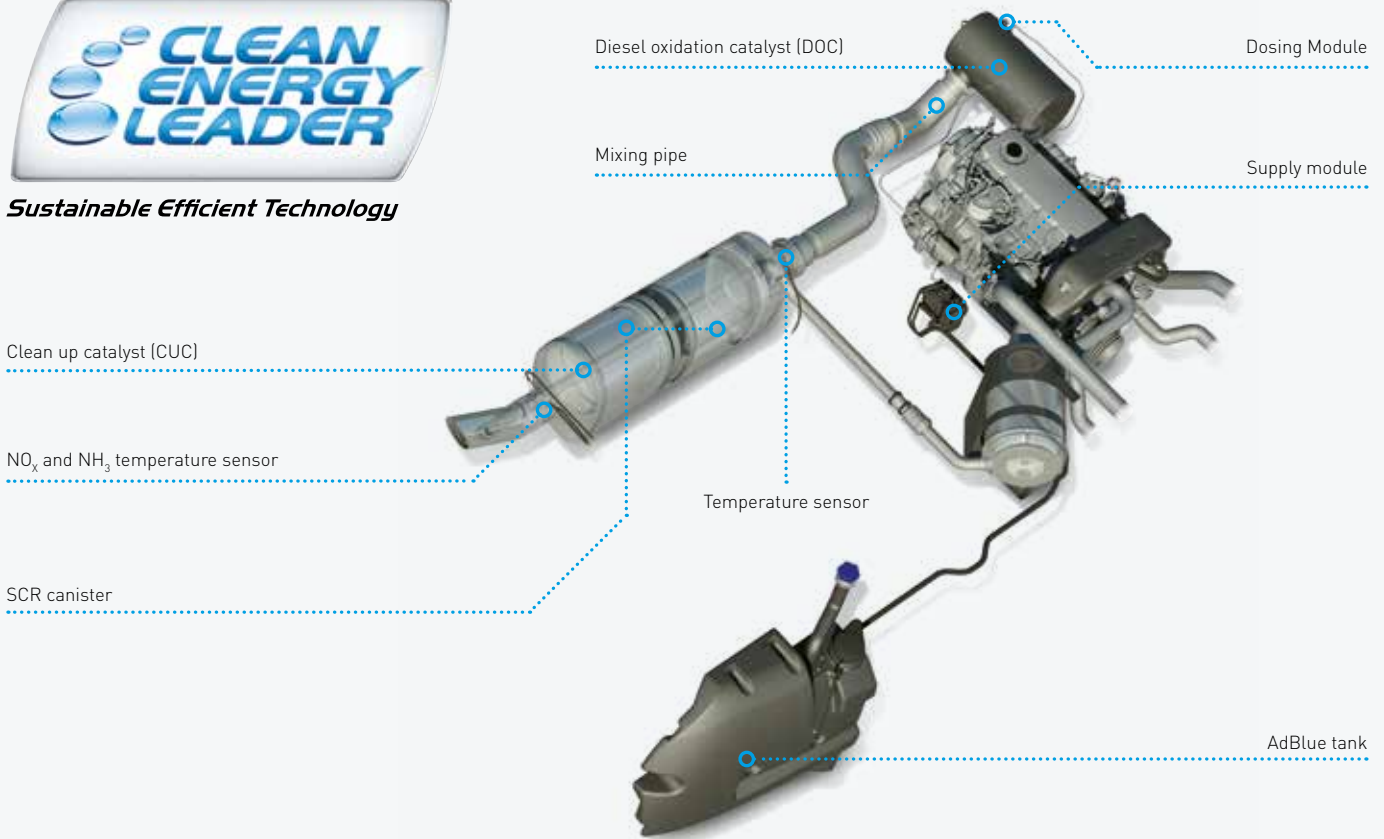

ECOBBlue HI-eSCR2



Basic models		CX5.80	CX5.90	CX6.80	CX6.90
Technology		common rail	common rail	common rail	common rail
Rated power	[kW/hp(CV)]	175/238	205/279	205/279	225/306
Maximum power	[kW/hp(CV)]	190/258	230/313	230/313	250/340
Governor		electronic	electronic	electronic	electronic



AdBlue with no added hassle

- AdBlue is a key component of the ECOBlue™ HI-eSCR 2 system
- AdBlue is a water and urea mix that is added to the exhaust gases to make them harmless
- Fill the AdBlue tank half as often as your diesel one
- Available through your New Holland dealer, you will be able to store AdBlue on your farm in a container size that suits your needs



Larger rear wheels and ultra low ground pressure

- New large steering wheels are available offering ground pressure as low as 1.2 bar and increased flotation and rolling ability in tough conditions
- A wide range of tyres can be specified to suit your individual needs



Unrestricted access

- Large hinged panels are easily raised for servicing, allowing quick and easy access
- Central grease banks further increase service accessibility and reduce service time



Power saving drivelines

- Low power consumption and ultimate reliability are the result of proven, direct drivelines and the 3-speed hydrostatic transmission
- All combines are constructed on an extremely robust frame, with superior material specifications, in line with Zedelgem tradition



Large cooling package

- The large radiator sections and the dust screen are easily accessible for thorough cleaning



Saving fuel during road travel - new road cruise mode

- For optimal fuel consumption, an automatic engine speed reducer adjusts engine rpm when travelling on the road

New Harvest Suite™ Deluxe cab.

Purpose developed for CX5 and CX6 combines, the new Harvest Suite™ Deluxe cab is 200mm wider and more spacious, an adjustable steering column and smaller steering wheel delivering improved ergonomics and even better visibility over the header. Additional work lights are standard, with detail improvements to include full-width hand rails over the front of the combine to facilitate cleaning through to new control buttons, two USB ports and an optional heated floor mat. Job data recording is now possible via the onboard printer option. The cab volume has increased to 3.7m³ and boasts 6.3m² of glass, and you can enjoy all that space in the peace and quiet of the near silent 73dB(A) cab. The new automotive inspired interior, features an ultramodern dark grey colour scheme, which has been extended to the headliner, armrest and rear bulkhead. With the new Harvest Suite™ Deluxe cab, there is truly luxury in space.



Optional remote folding mirror

- Remote folding and unfolding of the right-side mirror can be done from the cab
- Helps to save time and avoid damage when traveling on narrow roads and through gateways





LED portable work light

- New 12V wireless portable service light makes night time machine and sample checks safe and easy
- A magnetic base, LED's and a powerful 4400 mAh rechargeable battery make it an indispensable tool



Stay refreshed on the hottest days

- The large portable fridge under the instructor seat can be easily removed for replenishment
- Air conditioning comes as standard, or upgrade to the optional Automatic Climate Control system which automatically adjusts fan speed to guarantee accurate temperature control



Comfortable, safe and convenient

- Turntable ladder speeds access to the cab without getting in the way when not needed



360° panoramic view

- The Harvest Suite™ Deluxe cab's wide curved window offers a perfect view
- The floor slopes down into the front windscreen so that you have a clear view of the edge of the header
- Standard electric mirrors present a wide viewing arc to the sides and rear
- Up to three optional viewing cameras can be managed through the IntelliView™ IV monitor, and one has been prewired for reversing



In-cab view of grain tank

- A large glazed panel allows the operator to see into the grain tank for a visual check of sample quality and tank contents

Please, take a seat.

New Holland brings to you the best seat offering, with two different options providing you with a comprehensive choice in addition to a standard, full-sized upholstered instructor seat. All seats benefit from high quality cushions to provide outstanding comfort whatever the terrain.



Deluxe air suspended seat

- The top of the range two tone cloth trimmed air seat, featuring up to 45 degrees of angle adjustment to accommodate working over more severe slopes, is the obvious choice for Laterale and Hillside models. It features lumbar and damper adjustment, seat cushion angle and depth adjustment and also seat fore and aft adjustment to offer the ultimate in operator comfort and style



Standard seat

- The standard wide cloth trimmed air seat provides exceptional features and ensures all operators will stay comfortable throughout the longest harvesting day



The most powerful combine lighting package.

The CX5 and CX6 lighting package has raised the lighting bar, and can deliver up to a total of 48,000 lumens. The spread of light has been engineered for maximum visibility of the entire header and the field ahead. Precision unloading in the dead of night. You'll never lose a single grain thanks to specific unloading auger lights. You can also get off of your combine in complete safety courtesy of the entrance light, which remains on for 30 seconds after you've switched the combine off.



More light as standard with LED options

- Roof work lights are increased from three to four each side
- An optional 12 LED lighting package ensures the full width of the header and to the sides and behind is fully illuminated
- Two rear lights now come as standard on the straw hood



Easy to use

- Dedicated lighting control panel

Effortlessly maximising performance.

Automation saves time and boosts harvester performance. The multi-function lever on the CX5 & CX6 combine models is the proven CommandGrip™ handle. It is built into the console on the operator's right hand side. The position of this console is adjustable to suit the operator's preference and the CommandGrip™ is a forcebased propulsion handle that always comes back to its most ergonomic position irrespective of forward speed. It provides access to all major controls.

Cruise control and much more

One of the automatic functions that helps maintain high daily workrates is the Cruise Control: with a simple tap on one of the buttons on the CommandGrip™ handle, the combine resumes a set field speed.



Shift button and ground speed unlock (behind).



Force based movement enables the operator to change speed and direction.



Recommended Combine Settings RCS

- RCS eases the operators job of setting up the combine for different crops
- The RCS pages in the IntelliView™ IV monitor provide a reference guide, and display the basic parameters to set for a wide variety of crops
- RCS helps to ensure the machines capacity is being optimized at all times

Automatic Crop Setting ACS

- By pressing the ACS button on the RCS page, the operator can activate the basic RCS settings / customised saved settings
- The combine then automatically sets its parameters to the displayed values

Automatic functions save time

- Variator lubrication : activated via the IntelliView™ IV monitor when the threshing is engaged, the threshing drum variator is automatically opened and closed to distribute grease after daily greasing
- Automatic clean out: activated via the IntelliView™ IV screen when the threshing is engaged, all sieves are opened and the fan run at maximum rpm to clear out all chaff

Just touch the screen

Providing information on performance data, operational statistics and service data, the IntelliView™ IV monitor adds to optimising the combine's performance. The wide touchscreen is easy to use. One of the many time saving features available is the automatic crop setting function, whereby a specific combine setting can be stored for repetition when the same field situation pops up again.



Getting more from fertile ground.

Increasing yields, or saving money through reduced inputs: precision farming is a practice that makes use of site specific crop data in turn allowing optimum treatment and seed application in the subsequent periods. CX5 & CX6 combine models are ready to receive the equipment that supports this way of operating.

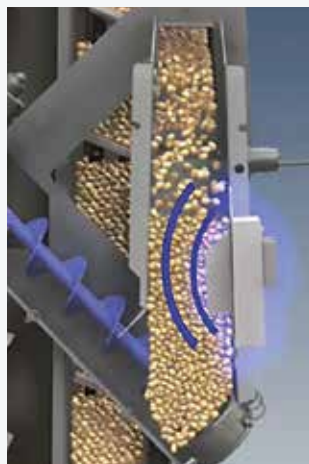

Yield and moisture sensors

Patented and exclusive to New Holland, the optional yield and moisture sensors not only deliver exceptional accuracy, they do not need to be re-calibrated when switching between different crops. The moisture sensor is mounted on the grain elevator where it regularly samples harvested grain, and the optical yield sensor is mounted inside the Clean Grain Elevator.

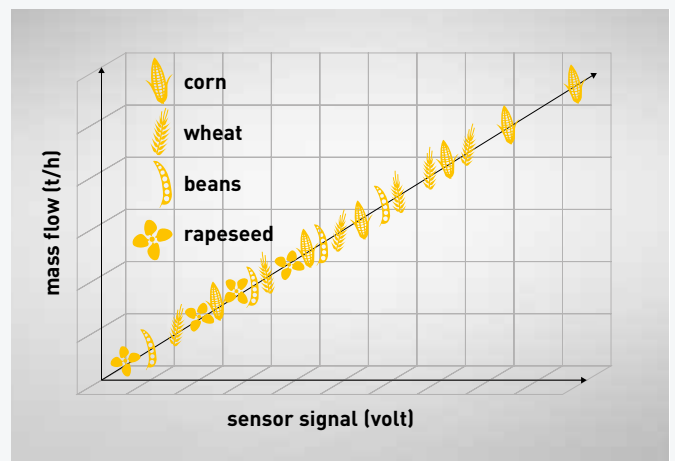

No calibration requirement

Thanks to the ingenuity of its concept, the unique New Holland yield sensor is extremely accurate whatever the crop, the variety or the moisture content of the kernel. There is no need for calibration between fields, crops or even between the cereal and maize season.

IntelliView™ IV - visible intelligence

The ultra-widescreen 26.4cm IntelliView™ IV colour touchscreen monitor can be used to manage the optional EZ-Pilot™ PRO auto-guidance system. You can personalize your settings simply and easily and also transfer data using MyPLM®Connect File Transfer and PLM desktop software packages.



New EZ-Pilot™ PRO guidance system

The new EZ-Pilot™ PRO guidance system combines the user-friendliness and integrated feel of the EZ-Pilot™ system with the intuitive functionality of the IntelliView™ IV touchscreen monitor. Mounted on the steering column, the system offers pass-on-pass and year-on-year repeatability as high as 1.5cm when used with an RTK correction signal.



MyPLM®Connect Telematics: manage your machine from the comfort of your office

MyPLM®Connect enables you to connect to your CX from the comfort of your office through the utilization of the mobile network. You can stay in touch with your machines at all times, and you can even send and receive real-time information that saves time and enhances productivity. The entry-level MyPLM®Connect Essential package offers the most frequently used features or upgrade to the MyPLM®Connect Professional package for full machine monitoring and control. In short, MyPLM®Connect will help you to reduce your fuel bills and improve fleet management and security in one simple package.



Real time data recording

New Holland offers a variety of precision farming packages which will enable you to tailor your inputs to reduce your costs and increase your yields. This information is recorded in real time by your machine during working, and it is simply and efficiently transferred for analysis by the computer package from the IntelliView™ IV monitor via the complementary 4GB USB stick, which is large enough to record data from over 600 - 700 harvesting hectares.



360°: CX5 & CX6.

The CX range has been designed to spend more time working and less time in the yard. After all, we all know how precious time in the field is during short harvesting seasons. All service points are easy to access, and long service intervals mean they will spend more time in the field.

The fuel and 110 litre AdBlue tanks are conveniently located next to each other to facilitate simultaneous filling.

Easy access to the wide opening rotary dust screens makes cleaning the cooling package a doddle.



Engine and hydraulic oil can be checked at a glance.



The air filter is easily accessible from the engine platform.



The integrated water tank is placed ideally for washing hands after connecting the header.

Easy ground-access to all oil filters and drain points and centralised greasing banks.

Self-supporting, fully opening shielding guarantees wide access to all drives and service points.



Dealer Installed Accessories

A comprehensive range of approved accessories can be supplied and fitted by your dealer.

New Holland Uptime Solutions.



Control Room

Using data from MyPLM®Connect, skilled technicians analyze specific triggers 24/7 to implement solutions as required. If an issue is identified, the system proactively sends an alert to dealers with the corrective action. If a New Holland dealer detects a potential failure, they can check parts availability and prepare for in-field servicing.



Assistance In Action

If the unthinkable happens and your combine stops during harvest, you need to get going ASAP. If you have a breakdown, we guarantee to activate our assistance process and to find the quickest and best solution for you.



Optimized parts availability

An advanced parts forecasting tool matches parts consumption data with external factors, such as the weather, crop yield and soil conditions, adapting parts availability to specific geographical areas. This tool enables dealers to carry the right level of stock, and also extends the window for them to place urgent orders. With track and trace technology, you can track parts in real time.



Uptime Warranty – because your peace of mind is priceless

The Uptime Warranty programme provides owners of New Holland machinery with repair services during the Manufacturer's contractual Warranty. Maximum control over operating costs, repairs completed by authorized New Holland Dealers using New Holland genuine parts, higher re-sale value of your machine and transferable coverage are all key benefits.



MyNew Holland™ will improve your daily work

MyNew Holland™ will improve your daily work: get access to exclusive information by adding your equipment, find online solutions for your PLM® products, download operator manuals. Whenever you want, wherever you want - and free of charge.

New Holland Style

Visit www.newhollandstyle.com. A whole range of items are available including hard wearing work clothing and a vast selection of scale models.

34 SPECIFICATIONS

Models		CX5.80	CX5.90	CX6.80	CX6.90
Grain header					
Cutting width: High Capacity grain header	(m)	4.57 - 7.32	4.57 - 7.32****	4.57 - 9.15	5.18 - 9.15
Heavy Duty Varifeed™ grain header [575mm of knife travel]	(m)	4.88 - 7.62	4.88 - 7.62****	4.88 - 9.15	4.88 - 9.15
High Capacity Hillside grain header	(m)	-	4.57 - 6.10	-	-
Knife speed	(cuts/min.)	1150	1150	1150	1150
Spare knife and spare bolted knife sections		●	●	●	●
Feeding auger with full-width retractable fingers		●	●	●	●
Reel diameter	(m)	1,07	1,07	1,07	1,07
Electro-hydraulic reel position adjustment		●	●	●	●
Automatic reel speed synchronisation to forward speed		●	●	●	●
Hydraulic quick coupler [single location]		●	●	●	●
Maize headers					
Flip-up maize headers	(number of rows)	6 - 8*****	6**** - 8*****	6*** - 8	6*** - 8***
Rigid maize headers	(number of rows)	5 - 6 - 8*****	5*** - 6 - 8*****	6 - 8	6 - 8
Remotely adjusted deck-plates		●	●	●	●
Integrated stalk choppers		○	○	○	○
Rotary dividers		○	○	○	○
Automatic row guidance		○	○	○	○
Automatic header control systems					
Stubble height control		automatic	automatic	automatic	automatic
Compensation		●	●	●	●
Autofloat™ II system		○	●	●	●
Straw elevator					
Number of chains		3	3	4	4
Header and elevator reverser		hydraulic	hydraulic****	hydraulic	hydraulic
Lateral flotation		○	●	●	●
Harvest Suite™ Deluxe cab					
LED working lighting pack		○	○	○	○
Standard cloth trimmed air-suspension seat		○	○	○	○
Deluxe air-suspension seat		○	○	○	○
Instructor's seat with removable coolbox [12V/220V]		●	●	●	●
IntelliView™ IV monitor		●	●	●	●
CommandGrip™ handle		●	●	●	●
Harvest Suite™ Deluxe cab glass area	(m²)	6.3	6.3	6.3	6.3
Up to 2 additional Viewing Camera's [on hitch & unloading tube]		○	○	○	○
Single rearview camera [on straw hood]		●	●	●	●
Recommend crop settings		●	●	●	●
Air-conditioning		●	●	●	●
Automatic climate control		○	○	○	○
Heating		○	○	○	○
Optimum cab noise level	(dB[A])	73	73	73	73
New Holland Precision Land Management systems					
Guidance systems					
EZ-Pilot™ PRO compatible with IntelliView™ IV monitor		○	○	○	○
Cruise Control mode		●	●	●	●
Automatic row guidance system for maize headers		○	○	○	○
Precision farming					
Moisture measuring		○	○	○	○
Yield measuring and moisture measuring		○	○	○	○
Full Precision farming package including: yield measuring and moisture measuring, DGPS yield mapping, desktop software and software support service		○	○	○	○
Threshing drum					
Width	(m)	1.3	1.3	1.56	1.56
Diameter	(m)	0.6	0.6	0.6	0.6
Standard type / Universal type		● / ○	● / ○	● / ○	● / ○
Number of bars		8	8	8	8
Speed range	(rpm)	400 - 1140	400 - 1140	400 - 1140	400 - 1140
Optional drum speed reductor	(rpm)	240 - 685	240 - 685	240 - 685	240 - 685
Concave					
Quick-change sectional concave		●	●	●	●
Area	(m²)	0.86	0.86	1.04	1.04
Number of bars		14	14	14	14
Angle of wrap Opti-Thresh™ system open	(°)	85	85	85	85
Angle of wrap Opti-Thresh™ system closed	(°)	121	121	121	121
Beater					
Four paddle / pins beater drum		● / ○	● / ○	● / ○	● / ○
Diameter	(m)	0.395	0.395	0.395	0.395
Beater concave area	(m²)	0.286	0.286	0.342	0.342
Synchronisation with drum speed		●	●	●	●
Rotary Separator					
Diameter	(m)	0.59	0.59	0.59	0.59
Speed	(rpm)	400 / 760	400 / 760	400 / 760	400 / 760
Quick speed change without tools		●	●	●	●
Concave area (including rake)	(m²)	0.84	0.84	1.01	1.01
Multi-Thresh™ system		●	●	●	●
Total powered separation area	(m²)	1.988	1.988	2.387	2.387
Straw Flow™ beater		●	●	●	●

Models	CX5.80	CX5.90	CX6.80	CX6.90
Strawwalkers				
Number	5	5	6	6
Separation area (m ²)	5.38	5.38	6.45	6.45
Opti-Speed™ variable strawwalkers	●	●	●	●
Cleaning				
Triple-Clean™ cascade system	●	●	●	●
Smart Sieve™ self levelling: cleaning system automatic kernel size adaptation	●	●****	●	●
Side slope correction on Pre- and Top Sieve (%)	25	25	25	25
Grainpan removable from front on Fix cleaning shoe	○	○	○	○
Grainpan removable from front on Smart Sieve™ cleaning shoe	●	●	●	●
Pre-cleaning system	●	●	●	●
Total area under wind control FS (m ²)	4.321	4.321	5.207	5.207
Remote control sieve setting	○	○	○	○
Levelling system				
Optional Laterale slope levelling system (Side-Hill) (%)	-	18	-	18
Wide Hillside levelling system (Side-Hill / Up-Hill / Down-Hill) - overall width = 4.0m (%)	-	38 / 30 / 10	-	-
Narrow Hillside levelling system (Side-Hill / Up-Hill / Down-Hill) - overall width = 3.5m (%)	-	32 / 30 / 10	-	-
Cleaning fan				
Opti-Fan™ system	●	●	●	●
Number of blades	6	6	6	6
Variable speed range - Optional Low (rpm)	165 - 420	165 - 420	165 - 420	165 - 420
- Standard High (rpm)	400 - 1000	400 - 1000	400 - 1000	400 - 1000
Electrical speed adjustment from the cab	●	●	●	●
Return system				
High Capacity grain elevator back to drum	●	●	●	●
Returns indication on IntelliView™ IV monitor	●	●	●	●
Grain elevator				
High Capacity grain elevator with heavy duty chain & flaps	●	●	●	●
Graintank				
Capacity / Hillside version (l)	8300	8300 / 7300	9300	9300
Central filling, folding bubble-up extension	●	●	●	●
Unloading auger				
Overtop unloading tube (4.75m)	●	●	○	○
Overtop unloading tube (5.50m)	○	○	●	●
Unloading speed / Hillside version (l/s)	90	100 / 90	100	100
Grain sample inspection door	●	●	●	●
Grain tank fill warning device	●	●	●	●
Unloading auger swivel reach (°)	105	105	105	105
New Holland engine*				
	Nef (6.7L)*	Nef (6.7L)*	Nef (6.7L)*	Cursor 9 (8.7L)*
Compliant with engine emissions regulations	Stage V	Stage V	Stage V	Stage V
ECObLue™ HI-eSCR 2 system (Selective Catalytic Reduction)	●	●	●	●
Injection system	common rail	common rail	common rail	common rail
Gross engine power @ 2100rpm - ISO 14396 - ECE R120 [kW/hp(CV)]	175/238	205/279	205/279	225/306
Maximum engine power @ 2000rpm - ISO 14396 - ECE R120 [kW/hp(CV)]	190/258	230/313	230/313	250/340
Approved biodiesel blend**	B20	B20	B20	B20
Governor type	electronic	electronic	electronic	electronic
Air compressor and air gun	○	○	○	○
Rotary dust screen blow off system	○	○	○	○
Fuel tanks				
Diesel Capacity / AdBlue Capacity (l)	670 / 110	670 / 110	670 / 110	670 / 110
Transmission				
	hydrostatic	hydrostatic	hydrostatic	hydrostatic
Gearbox	3-speed	3-speed	3-speed	3-speed
Hydrostatic hytron pump control	electronic	electronic	electronic	electronic
In-line gearshifting	●	●	●	●
Cruise Control mode	●	●	●	●
Differential lock	○	○****	○	○***
Powered rear wheels	○	○	○	○
Maximum speed (kph)	30	30	30	30
Residue management				
Dual-Chop™ straw chopper	●	●	●	●
Remote adjustable deflectors	●	●	●	●
Adjustable chaff spreader	●	●	●	●
Dimensions				
With traction wheels*****	650/75-R32	710/75-R34	710/75-R34	710/75-R34
Maximum height in transport position (m)	3.930	3.990****	3.990	3.990
Maximum width - transport (m)	3.275	3.265****	3.500	3.500***
Maximum length with extended unloading tube without header (m)	8.760	8.760	8.760	8.760
Weight				
Standard version less header and less straw chopper (kg)	12300	12400	13200	13400
Hillside version less header and less straw chopper (kg)	-	14000	-	-
Laterale version less header and less straw chopper (kg)	-	13900	-	14700

● Standard ○ Optional - Not available

* Developed by FPT Industrial

** Biodiesel blend must fully comply with the latest fuel specification EN14214:2009 and operation is in accordance with operator manual guidelines

*** Not available on Laterale versions

**** Not available on Hillside version

***** Traction wheels other than those mentioned are also available, depending on the market (620/75-R30; 320/75-R34; 800/65-R32; 900/60-R32; 30.5x32; 1050/50-R32)

***** Only in combination with specific tyre size and on flat field conditions

New Holland Top Service: customer support and customer information.



Top Availability

If you need information, or have an out of hours question, ring our toll-free number*. All day, every day, we are just a call away.



Top Speed

Express parts delivery: when you need it, where you need it!



Top Priority

Fast-track solution during the season: because your harvest can't wait!



Top Satisfaction

We drive and track the solution you need, keeping you informed: until you are 100% satisfied!



For more details, ask your New Holland dealer!

* Calls to the Top Service team are free from landlines in the United Kingdom and Republic of Ireland. UK-based mobile calls are also free, but Republic of Ireland mobile users should call 01 2421881 and this will be charged at your standard network rate.

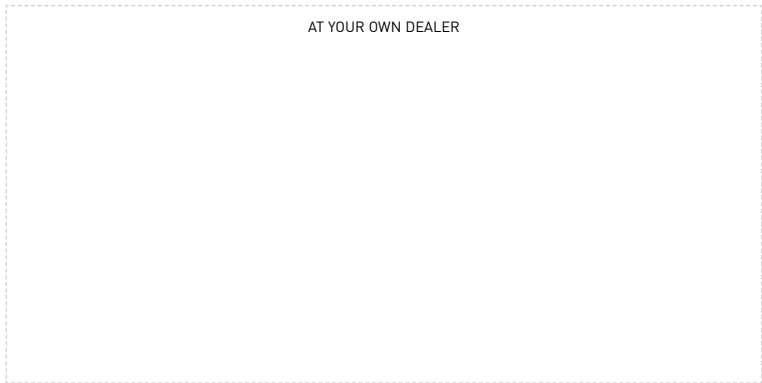

www.newholland.com/uk - www.newholland.com/ie

